

Solutions for stone working

A step ahead to your success



CERATIZIT is a high-tech engineering group specialised in tooling and hard material technologies.

Tooling the Future

www.cerazit.com

Dear valued customer,

We would like to present you with our new catalogue for stone working products. It contains all the standard products manufactured by CERATIZIT.

Toolmaker Solutions by CERATIZIT can offer you even more than our standard products range! Get a competitive head start, and benefit from decades of experience in the development of customised solutions for the machining of concrete, ferro-concrete, stone, masonry and other materials. Thanks to our engineering team, we offer everything tool manufacturers need. Innovation, new developments, high value and quality products and service are our core business.

Because your needs are important to us, we work together with you to find the ideal solution for your application and requirements. You can rest assured that with us you are not just a customer but a partner.

Yours,

the Toolmaker Solutions by CERATIZIT team



Content

Introduction	
CERATIZIT Group	5
Cemented Carbide	6–9
Carbide properties	10
Production site	11
Grades for stone working	
Grades for stone working	12–14
Composition and properties	15
Innovation	
Innovation – Products developed with our customers	16–17
Innovation – Project management in collaboration with the customer	18–19
Hammer drill tips	
Index	21
Grades for stone working	22
Applications	23
Hammer drill tips	24–35
Masonry drill tips	
Index	37
Grades for stone working	38
Applications	39
CERATIZIT Style 58000	40
Masonry drill tips	41–57
Special tips	
Index	59
Metal cutting tips	60–61
Blanks for wood machining drill tips	62–65
Glass drill tips	66–67
Core drill tips	
Index	69
Grades for stone working	70
Core drill tips	71–73
Fluterolls for drill production	
Fluterolls	74–75
Powder & grit	
Powder & grit	76–77
Index	
Index	78

CERATIZIT Group

For over **95 years**, CERATIZIT has been a **pioneer** developing exceptional hard material products for cutting tools and wear protection. The privately owned company, based in Mamer, Luxembourg, develops and manufactures highly specialised carbide cutting tools, inserts and rods made of hard materials as well as wear parts.

The CERATIZIT Group is the **market leader** in several wear part application areas, and successfully develops new types of cemented carbide, cermet and ceramic grades which are used for instance in the wood, metal and stone working industry.

Facts and figures

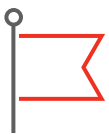

1 headquarters
Mamer / Luxembourg

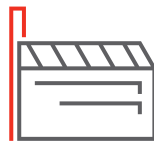

34
production sites



> 70
sales subsidiaries



> 9,000
employees



> 100,000
different products



> 1,000
patents and
utility models



> 200
employees in R&D



> 10
innovation awards



30%
of products developed
in the last 5 years

Cemented carbide

Cemented carbides are composite materials consisting of a hard material and a comparatively soft binder metal, like cobalt (Co). The performance characteristics of carbide are determined by hardness, transverse rupture strength and fracture toughness. With regard to their application, important parameters for the optimisation of these characteristics are the cobalt content and the grain size of the metal binder phase. The tungsten carbide grains have an average size of less than 0.2µm up to several micrometres (µm). The cobalt

fills the gaps between the carbide grains. When extremely high toughness is required, the cobalt content can amount to as much to 30%, whereas, for maximum wear resistance, the cobalt content is reduced and the grain size decreased to the nanocrystalline range of < 0.2µm.

CERATIZIT produces far more than 100 different cemented carbide grades particularly for wear parts and cutting tools, thus offering a customised solution for every application.



Carbide production

Carbide production at CERATIZIT started in 1929. Last but not least, thanks to long-standing experience CERATIZIT handles the entire process chain, from the raw material to the dispatching of the finished products to customers. The production process of powder-metallurgical products basically includes the four steps of powder preparation, shaping, sintering and finishing.

Tungsten carbide production

The ammonium para-tungstate (APT) is calcined into tungsten oxide under high temperature. Subsequently the oxide is reduced to tungsten metal in a hydrogen atmosphere. The metal powder is then mixed with carbon and carburised under inert atmosphere at high temperatures. The production parameters are decisive for the WC grain size in the sintered carbide.

Powder preparation

The tungsten carbide is intensely mixed with the binder metal cobalt, nickel or iron, various grain growth inhibitors and special alloys as well as materials, which promote compaction, by wet grinding so that a homogeneous suspension is created. Afterwards, the suspension is dried in a spray tower to produce a granulate with good flow characteristics. This granulate represents the basis for all forming processes.

APT (ammonium para-tungstate)



Yellow tungsten oxide



Blue tungsten oxide



Tungsten

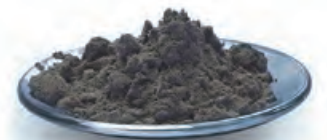

Tungsten carbide



Metal forming – pressing – machining

Metal forming

The objective of the forming process is to obtain a near net shape sample. Pressing is normally carried out at room temperature with pressures reaching up to several tons per square centimetre.

There are several ways of pressing blanks:

During isostatic cold pressing the powder is filled into an elastic flexible hose and pressed into a compacted form through high liquid pressure. The powder blocks which are produced in this way can then be processed mechanically. All common machining methods like milling, cutting, drilling or turning may be applied.

In uniaxial pressing the pressing tool consists of a die and an upper and a lower punch. The carbide powder is filled into the die and then compacted to create the so called green carbide, which is ejected from the pressing die.

Extrusion pressing is mainly used to produce rectangular bar or cylindrical rod, with or without axial hole(s). A plasticiser is added to the powder. The resulting paste is pressed through an extrusion nozzle. Before sintering, the plasticiser must be evaporated in special drying furnaces.

Metal Injection Moulding (MIM) is a process used to produce more complex forms which cannot be produced by direct pressing. The paste preparation is similar to the extrusion process.



Sintering

Sintering process

The sintering process converts the blank into a homogeneous and dense carbide with a high level of hardness. The material is sintered at temperatures between 1,300 and 1,500 °C (liquid phase sintering) and sometimes also at high pressure (up to 100 bar). The volume is reduced by up to 50% during this process.

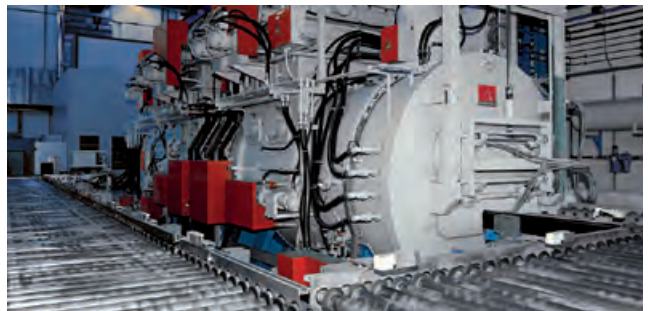

Carbide properties depending on the Co contents and C grain size

Hardness (wear resistance)

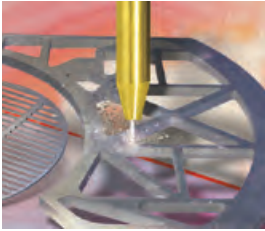

Nozzles for water jet cutting

Type of stress

- ▲ Wear
- ▲ Corrosion

Carbide grade

- ▲ Very high hardness: 2650 HV₃₀
- ▲ Small grain size: < 0.5 μm
- ▲ Low Co content: 0.4%
- ▲ Corrosion resistance when adding Cr₃C₂

Hardness

Cobalt content ↓ ↓
Grain size ↓ ↓

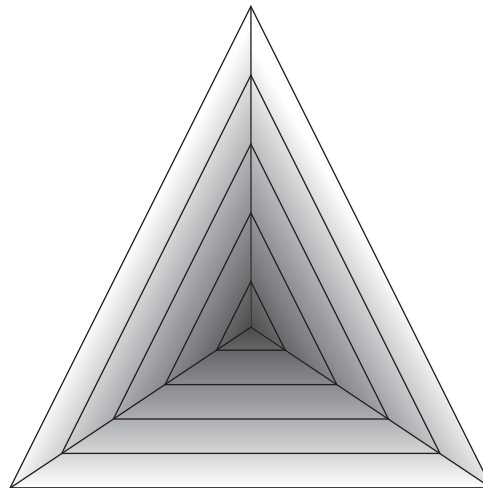

Transverse rupture strength

Cobalt content ↑ ↑
Grain size ↓ ↓

Toughness

Cobalt content ↑ ↑
Grain size ↑ ↑

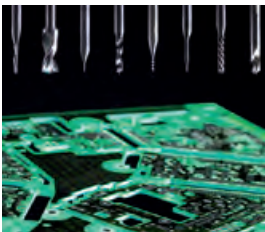

Transverse rupture strength



Toughness

Micro-drilling

Type of stress

- ▲ Wear
- ▲ Deflection

Carbide grade

- ▲ T.R.S.: > 4000 MPa
- ▲ Small grain size: < 0.5 μm + VC
- ▲ Low Co content ~ 8.5%
- ▲ High wear resistance: 1930 HV₃₀

Hot rolling

Type of stress

- ▲ Wear due to abrasion
- ▲ Built-up edge
- ▲ Impact stress

Carbide grade

- ▲ Sufficient fracture toughness: Co content 20%
- ▲ Good wear resistance: 1030 HV₃₀
- ▲ Medium grain size coarse or extra-coarse

Production site



Mamer, Luxembourg

The CERATIZIT Group has its headquarters in Mamer, Luxembourg. Today the plant in Mamer has more than 1,300 employees and concentrates on industrial wear protection, wood, metal and stone working as well as inserts and tools.



Grades for stone working
Sorten für Steinbearbeitung
Nuances pour les applications de la pierre
Gradi applicazioni pietra
Calidades para piedra



Carbide is a hard material with mechanical properties that can be adjusted within a very wide range, given its composition and microstructure. The hardness and toughness range of the CERATIZIT grades includes everything from wear-resistant tool steel to super-hard ceramic materials.

Criteria relevant for application

- ▲ Wear resistance, hardness
- ▲ Compressive strength
- ▲ Impact strength
- ▲ Transverse rupture strength
- ▲ Tribological properties
- ▲ Specific weight
- ▲ Magnetic properties
- ▲ Modulus of elasticity, rigidity
- ▲ Thermal properties
- ▲ Corrosion resistance, resistance to oxidation
- ▲ Toughness

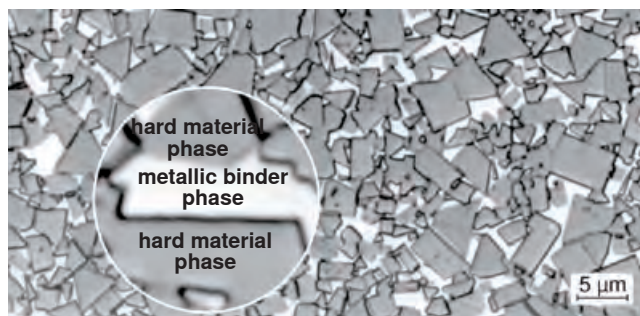

Micrograph of WC-Co carbide

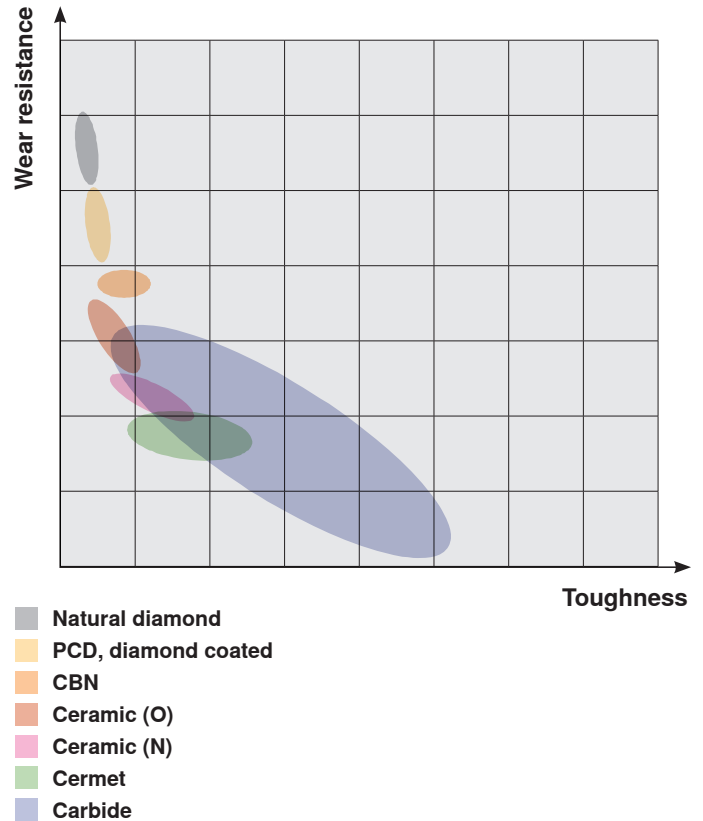

The hard material provides the necessary

- ▲ Hardness
- ▲ Wear resistance

The metallic binder provides

- ▲ Toughness

The graphic illustrations below show that the mechanical properties of the carbide mainly depend on the binder content (Co) and the TC grain size. Hardness, i.e. wear resistance, increases inversely proportional to the fracture toughness. This means that the harder the material the more it reacts to notch tensions and impact stress (the 'impact resistance' parameter, which cannot be precisely defined, correlates with the fracture toughness of the material). On the other hand, the transverse rupture strength does not

directly depend on the hardness but rather on the TC grain size and the cobalt content. The adhesive wear (tendency to stick), however, decreases with the grain size and the cobalt content of the carbide used. The list of the mentioned interdependencies, which could be extended at will for other wear and failure mechanisms, show that it is only possible to choose the correct carbide grade following a systematic procedure and/or based on experience with similar applications.

Ultrafine grain

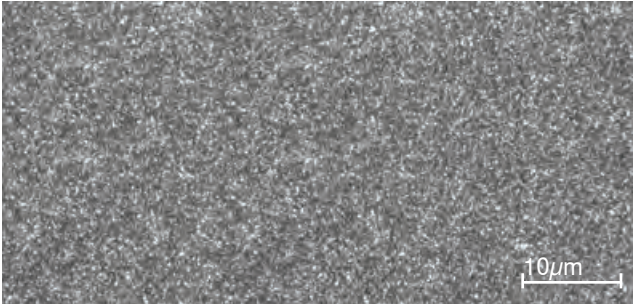

Submicron grain

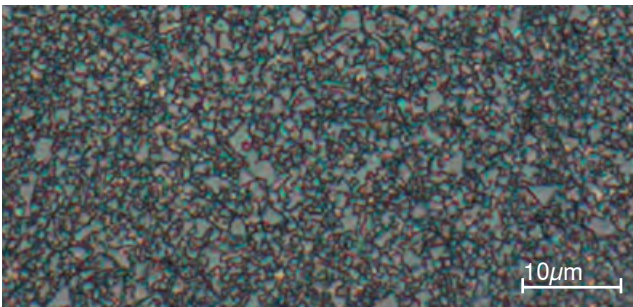

Fine / medium grain

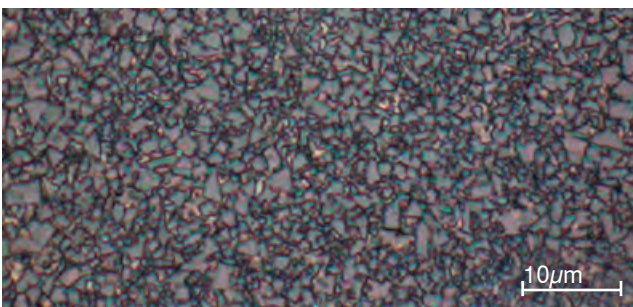

Coarse grain

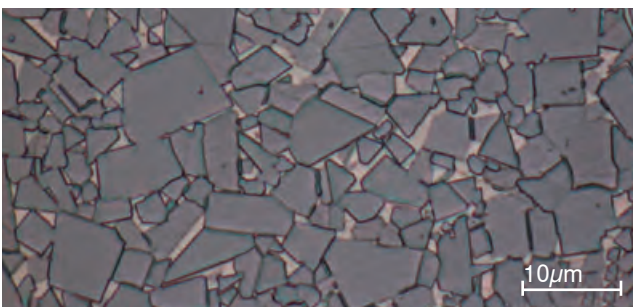

Hardness [HV30]

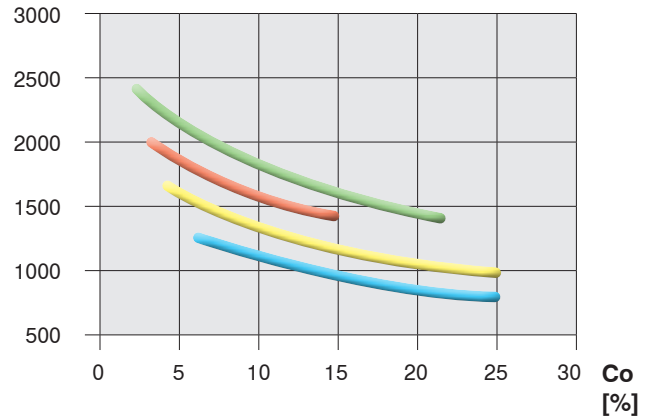

Transverse rupture strength [MPa]

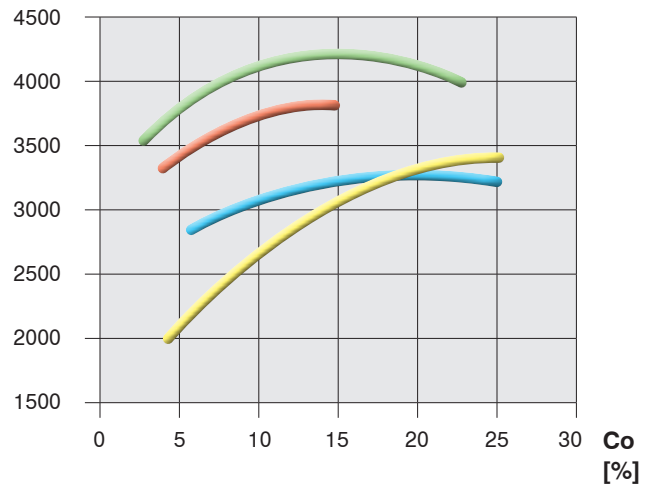

K^{IC} value [MPa.m^{1/2}]

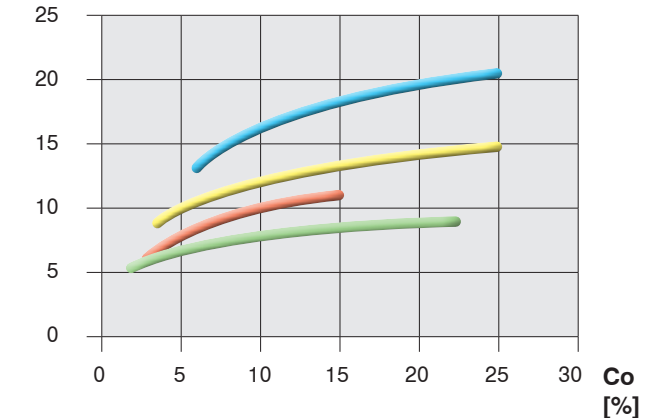

- Ultrafine grade
- Fine / medium grain
- Submicron grain
- Coarse grain

Composition and properties

Chromium grade

CERATIZIT grade code	ISO code	U.S. code	Binder [m %]	Density [g/cm ³]	Hardness			Transverse Rupture Strength	
					HV10	HV30	HRA	[MPa]	[P.S.I.]
Submicron grain									
CTS06-KC	KCR06	–	3.0	15.30	1950	1910	93.6	2300	334.000

WC-Cobalt Grades

CERATIZIT grade code	ISO code	U.S. code	Binder [m %]	Density [g/cm ³]	Hardness			Transverse Rupture Strength	
					HV10	HV30	HRA	[MPa]	[P.S.I.]
Submicron grain									
CTS20-BC	MG18	–	10	14.45	1680	1660	92.3	3700	537.000

Fine grain

CTF08-BC	BC01	–	4.0	15.15	1845	1815	93.1	2050	298.000
CTF11-BC	BC03	–	5.6	14.95	1760	1730	92.7	2150	312.000
CTF12-BC	BC05	C2	6.0	14.95	1640	1620	92.1	2200	319.000
CTF24-BC	BC30	C11	12.0	14.30	1330	1320	89.7	3000	435.000
CTF30-BC	BC40	C13	15.0	14.05	1250	1240	88.8	3100	450.000

Medium grain

CTM14-BC	BC10	C2	7.0	14.90	1550	1530	91.5	2600	377.000
CTM17-BC	HC30/BC20	C1	8.5	14.65	1420	1400	90.4	2800	406.000
CTM18-BC	HC35	C1	9.0	14.60	1400	1380	90.3	2800	406.000

Coarse grain

CTE20-BC	BC45	–	10.0	14.60	1130	1120	87.6	2600	377.000
CTE30-BC	BC50	C14	15.0	14.05	970	960	85.6	2800	406.000
CTE35-BC	BC55	–	17.5	13.80	920	910	85.0	2850	414.000

Note: BC: used for stone
HC: used for wood

Classification of the WC grain size

Average grain size [μm]	Classification	CERATIZIT- code
< 0.2	nano	N
0.2 – < 0.5	ultrafine	U
0.5 – < 0.8	submicron	S
0.8 – < 1.3	fine	F
1.3 – < 2.5	medium	M
2.5 – < 6.0	coarse	C
> 6.0	extra-coarse	E

Innovation
Innovation
Innovation
Innovazione
Innovación



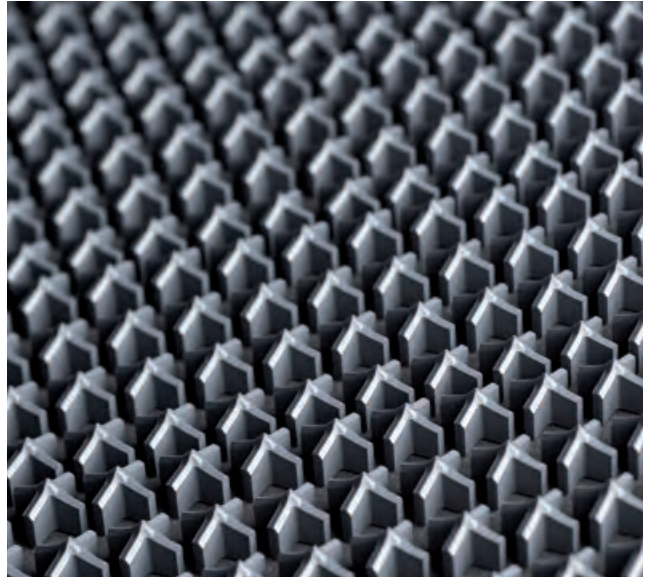
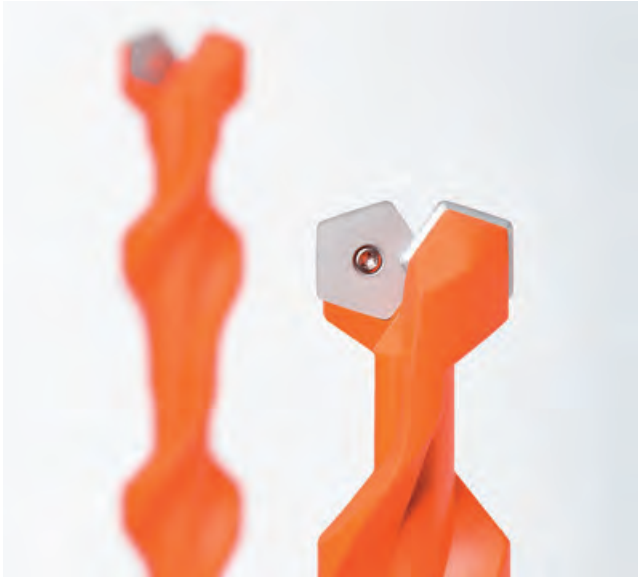

Project management in collaboration with our customers

Welcome on board!

The Toolmaker Solutions by CERATIZIT team is happy to invite you to join us on an innovative journey!

Let us guide you through all the project steps leading to your success. Thanks to our engineering expertise, we can take your ideas and concepts through to the desired destination – your customers. We will travel together through the different steps of this trip, from feasibility study to prototypes and finally to serial production.

Our target is to guide you all along the way in developing new products or improving existing ones. We will take care of your project thanks to our supreme carbide experience, ground production experts and our engineering team.

So on each step of the way you will be provided with innovative carbide solutions tailored to your own manufactured tools.

Let's go!



Meeting between the customer and product managers



Feasibility study



Prototype



Serial production



Customer test and approval

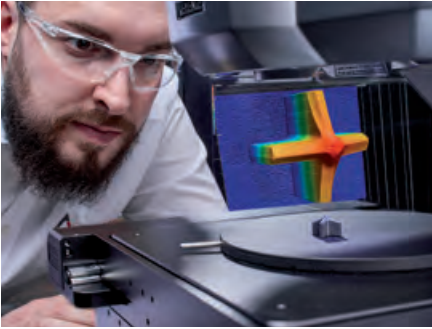

Quality control

A step ahead to your success

Hammer drill tips

Hammerbohrerplatten

Plaquettes pour mèche marteau

Placchette per punte a percussione

Puntas de brocas para percusion

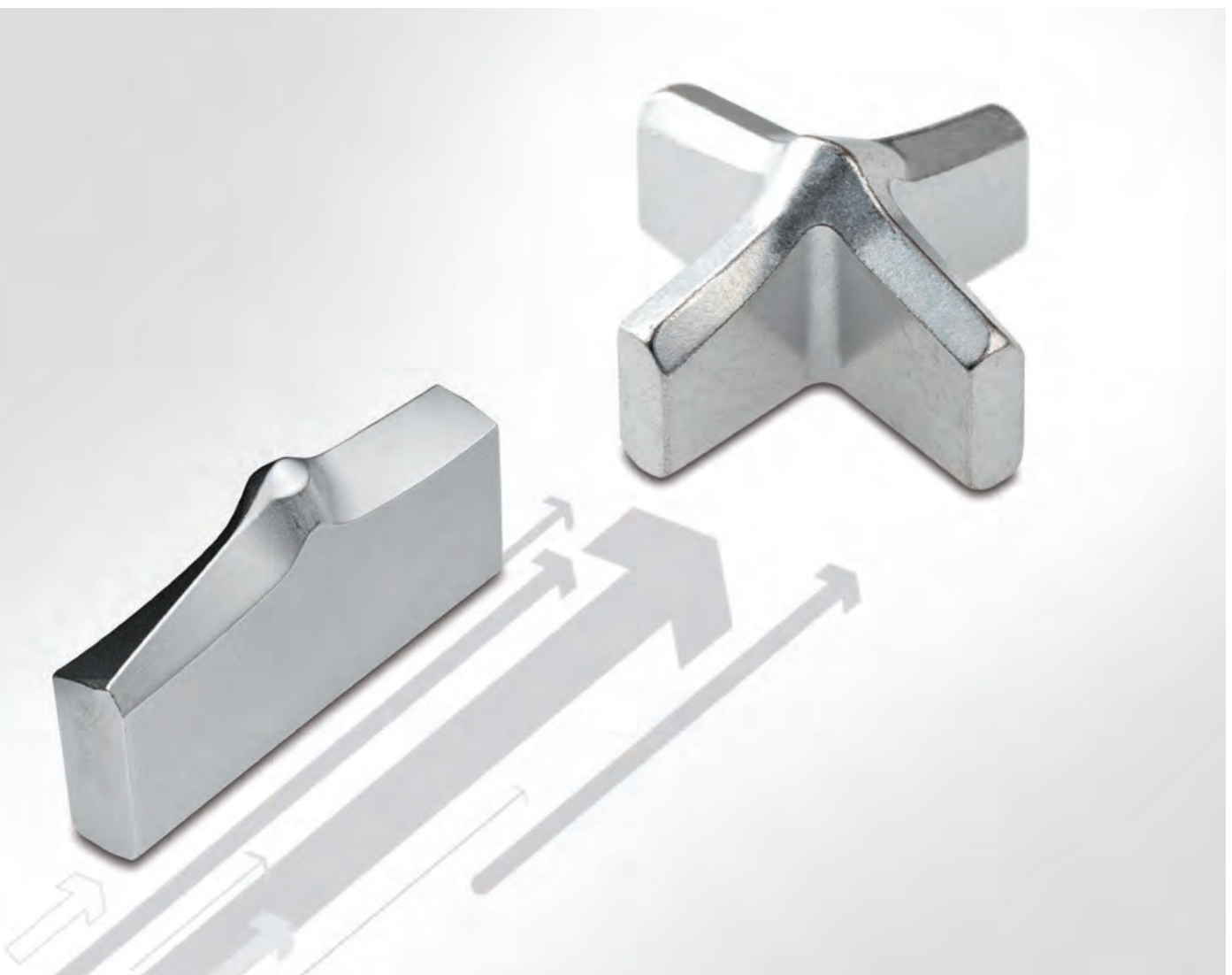

Index

Grades					Page
Composition and properties					22
Applications					23

Premium Hammer Drill Tips	Style	Range Ø	Specificity	PGM Conformity	Page
CT4	METRIC (Ø mm)	5 – 35			24
CT4	ANSI (Ø inch)	1/2" – 1 3/8"			25
CT4	JAPAN (Ø mm)	6.4 – 16.5			25
46000	METRIC (Ø mm)	4 – 52		✓	26
46600	ANSI (Ø inch)	1/8" – 2"			27
47500	JAPAN (Ø mm)	3.4 – 22			28

Standard Hammer Drill Tips	Style	Range Ø	Specificity	PGM Conformity	Page
50850	METRIC (Ø mm)	4 – 20		✓	29
50850	ANSI (Ø inch)	5/32" – 5/16"			29
11384	METRIC (Ø mm)	4 – 52	130°	✓	30
17871	ANSI (Ø inch)	1/8" – 2"	130°		31–32
26000	JAPAN (Ø mm)	4 – 22	130°		33

Special Hammer Drill Tips	Style	Range Ø	Specificity	PGM Conformity	Page
14444	METRIC (Ø mm)	4 – 8/	130°		34
38500	METRIC (Ø mm)	3 – 4.5	130°		34
38911	METRIC (Ø mm)	4 – 6	130°		34
39742	METRIC (Ø mm)	3.5	130°		35
40429	METRIC (Ø mm)	3.5	130°		35

Grades for stone working – composition and properties

HAMMER	CERATIZIT grade code	ISO code	Grain	%Co	HV10	TRS
Small Diameter	CTM17-BC	BC20	M	8.5	1420	2900
Large Diameter	CTM17-BC	BC20	M	8.5	1420	2800
Special for low impact	CTM14-BC	BC10	M	7.0	1550	2600
Special for heavy duty	CTF24-BC	BC30	F	12.0	1330	3000

MASONRY	CERATIZIT grade code	ISO code	Grain	%Co	HV10	TRS
Small Diameter	CTF11-BC	BC03	F	5.6	1760	2300
Large Diameter	CTF12-BC	BC05	F	6.0	1640	2200
Special for low impact	CTF08-BC	BC01	F	4.0	1840	2200
Special for heavy duty	CTM14-BC	BC10	M	7.0	1550	2600

Classification of the WC grain size

Average grain size [µm]	Classification	CERATIZIT-code
< 0.2	nano	N
0.2 – < 0.5	ultrafine	U
0.5 – < 0.8	submicron	S
0.8 – < 1.3	fine	F
1.3 – < 2.5	medium	M
2.5 – < 6.0	coarse	C
> 6.0	extra-coarse	E

Applications



Type, description	METRIC	ANSI	JAPAN	PGM	Rebar	Concrete	Stone & Rock	Bricks	Blocks	Granit & Marble
CT4	✓	✓	✓			●	●	●	●	●
46000	✓			✓	●	●	●	●	●	
46600		✓			●	●	●	●	●	
47500			✓		●	●	●	●	●	
50850	✓			✓	●	●	●	●	●	
50850		✓			●	●	●	●	●	
11384	✓			✓	●	●	●	●	●	●
17871		✓			●	●	●	●	●	●
26000			✓		●	●	●	●	●	●
14444	✓				●	●	●	●	●	●
38500	✓				●	●	●	●	●	●
38911	✓				●	●	●	●	●	●
39742	✓				●	●	●	●	●	●
40429	✓				●	●	●	●	●	●

● Optimum
○ Not optimum

Hammer drill tips – METRIC CT4

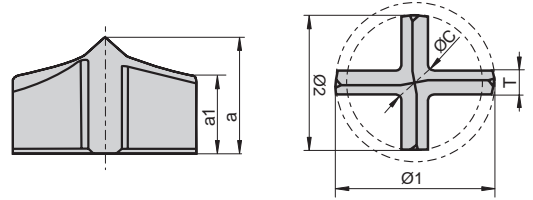

Ø [mm]	Height a [mm]	Height Tol. [mm]	Height a1 [mm]	Ø 1 [mm]	Ø1 Tol. [mm]	Ø 2 [mm]	Ø2 Tol. [mm]	Cent. Ø [mm]	Thickness [mm]
5.00	4.100	±0.10	2.980	5.285	±0.075	5.085	±0.075	1.590	0.950
5.50	4.550	±0.10	3.270	5.785	±0.075	5.585	±0.075	1.590	0.950
6.00	4.850	±0.10	3.530	6.285	±0.075	6.085	±0.075	1.960	1.150
6.50	5.200	±0.10	3.820	6.725	±0.075	6.525	±0.075	1.960	1.150
7.00	5.550	±0.10	4.090	7.285	±0.075	7.085	±0.075	1.960	1.150
8.00	5.650	±0.15	3.940	8.285	±0.075	8.085	±0.075	2.610	1.550
10.00	7.050	±0.15	4.850	10.300	±0.090	10.000	±0.090	2.890	1.750
12.00	8.500	±0.15	5.820	12.340	±0.090	12.040	±0.090	3.250	1.950
14.00	9.900	±0.15	6.770	14.355	±0.105	14.055	±0.105	3.500	2.125
16.00	9.650	±0.15	6.070	16.355	±0.105	16.055	±0.105	4.090	2.425
18.00	11.400	±0.25	6.950	18.355	±0.105	17.955	±0.105	4.800	2.925
20.00	12.550	±0.25	7.670	20.430	±0.120	20.030	±0.120	4.800	2.925
22.00	12.700	±0.25	7.330	22.380	±0.120	21.980	±0.120	5.640	3.400
23.00	13.100	±0.25	7.600	23.380	±0.120	22.880	±0.120	5.640	3.400
24.00	13.800	±0.25	7.920	24.380	±0.120	23.880	±0.120	5.640	3.400
25.00	14.300	±0.25	8.280	25.380	±0.120	24.880	±0.120	5.640	3.400
26.00	14.750	±0.25	8.600	26.380	±0.120	25.880	±0.120	5.640	3.400
28.00	15.950	±0.25	9.230	28.380	±0.120	27.880	±0.120	6.510	3.900
30.00	17.000	±0.25	9.870	30.380	±0.120	29.880	±0.120	6.510	3.900
32.00	18.150	±0.25	10.510	32.520	±0.150	31.770	±0.150	7.380	4.400
35.00	19.350	±0.25	11.460	35.520	±0.150	34.770	±0.150	7.380	4.400

Codification code example: CT4- 5.00 CTM17-BC

Hammer drill tips – ANSI

CT4

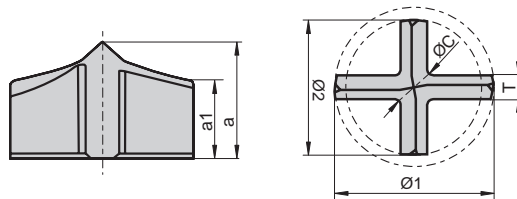

Ø [inch]	Height a [mm]	Height Tol. [mm]	Height a1 [mm]	Ø 1 [mm]	Ø1 Tol. [mm]	Ø 2 [mm]	Ø2 Tol. [mm]	Cent. Ø [mm]	Thickness [mm]
1/2"	9.15	±0.10	5.99	13.31	±0.10	12.90	±0.10	3.50	2.125
9/16"	10.25	±0.10	6.74	14.89	±0.10	14.50	±0.10	3.50	2.125
5/8"	9.85	±0.10	5.90	16.61	±0.10	16.20	±0.10	4.09	2.425
3/4"	11.55	±0.10	6.74	19.84	±0.15	19.44	±0.15	4.80	2.925
7/8"	12.15	±0.10	6.68	23.14	±0.15	22.64	±0.15	5.64	3.400
1"	13.25	±0.10	7.11	26.32	±0.15	25.82	±0.15	5.64	3.400
1 1/8"	14.70	±0.10	7.67	29.66	±0.19	29.16	±0.19	6.51	3.900
1 1/4"	16.80	±0.10	9.12	32.83	±0.19	32.08	±0.19	7.38	4.400
1 3/8"	16.80	±0.10	8.84	36.01	±0.19	35.26	±0.19	7.38	4.400

Codification code example: CT4- 1/2" CTM17-BC

Hammer drill tips – JAPAN

CT4

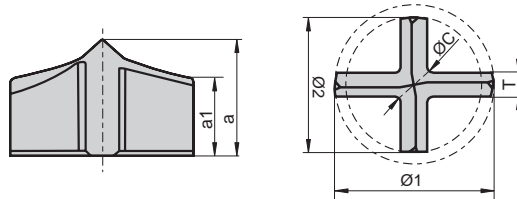

Ø [mm]	Height a [mm]	Height Tol. [mm]	Height a1 [mm]	Ø 1 [mm]	Ø1 Tol. [mm]	Ø 2 [mm]	Ø2 Tol. [mm]	Cent. Ø [mm]	Thickness [mm]
6.40	5.250	±0.10	3.780	6.525	±0.125	6.325	±0.125	1.960	1.150
8.00	5.950	±0.15	4.060	8.125	±0.125	7.925	±0.125	2.610	1.550
8.50	6.150	±0.15	4.180	8.625	±0.125	8.325	±0.125	2.610	1.550
10.50	7.400	±0.15	5.120	10.650	±0.15	10.350	±0.15	2.890	1.750
12.50	9.000	±0.15	6.050	12.650	±0.15	12.350	±0.15	3.250	1.950
12.70	9.100	±0.15	6.140	12.850	±0.15	12.550	±0.15	3.250	1.950
14.50	10.450	±0.15	6.970	14.650	±0.15	14.350	±0.15	3.500	2.125
16.50	10.100	±0.25	6.370	16.650	±0.15	16.350	±0.15	4.090	2.425

Codification code example: CT4- 6.40 CTM17-BC

Hammer drill tips – METRIC 46000

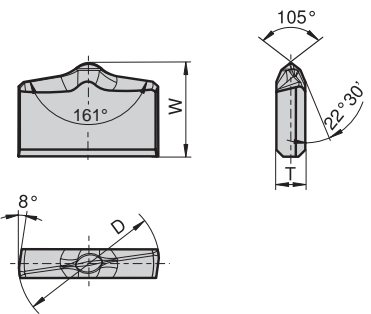

Ø [mm]	D [mm]	Tol. [mm]	W [mm]	Tol. [mm]	T [mm]	Tol. [mm]
4.00	4.285	±0.075	4.15	±0.10	0.950	±0.05
5.00	5.285	±0.075	4.65	±0.10	1.350	±0.05
5.50	5.785	±0.075	4.95	±0.10	1.350	±0.05
6.00	6.285	±0.075	4.85	±0.10	1.550	±0.05
6.50	6.725	±0.075	5.30	±0.10	1.550	±0.05
7.00	7.285	±0.075	5.35	±0.10	1.550	±0.05
8.00	8.285	±0.075	5.95	±0.15	1.950	±0.05
8.50	8.740	±0.09	6.30	±0.15	1.950	±0.05
9.00	9.300	±0.09	6.30	±0.15	1.950	±0.05
10.00	10.300	±0.09	6.85	±0.15	2.125	±0.075
10.50	10.800	±0.09	7.30	±0.15	2.125	±0.075
11.00	11.340	±0.09	7.70	±0.15	2.125	±0.075
12.00	12.340	±0.09	8.25	±0.15	2.425	±0.075
13.00	13.355	±0.105	8.70	±0.15	2.725	±0.075
14.00	14.355	±0.105	8.95	±0.15	2.925	±0.075
15.00	15.355	±0.105	9.35	±0.15	2.925	±0.075
16.00	16.355	±0.105	9.35	±0.15	2.925	±0.075
17.00	17.355	±0.105	9.35	±0.15	2.925	±0.075
18.00	18.355	±0.105	9.65	±0.25	3.400	±0.10
19.00	19.430	±0.12	10.40	±0.25	3.400	±0.10
20.00	20.430	±0.12	11.25	±0.25	3.400	±0.10
22.00	22.380	±0.12	12.30	±0.25	3.900	±0.10
23.00	23.380	±0.12	12.30	±0.25	3.900	±0.10
24.00	24.380	±0.12	13.30	±0.25	4.400	±0.10
25.00	25.380	±0.12	13.25	±0.25	4.400	±0.10
26.00	26.380	±0.12	13.25	±0.25	4.400	±0.10
28.00	28.380	±0.12	14.70	±0.25	4.900	±0.10
29.00	29.380	±0.12	14.70	±0.25	4.900	±0.10
30.00	30.380	±0.12	14.70	±0.25	4.900	±0.10
32.00	32.520	±0.15	16.80	±0.25	5.400	±0.10
35.00	35.520	±0.15	18.00	±0.25	5.900	±0.10
36.00	36.520	±0.15	18.25	±0.25	5.900	±0.10
38.00	38.570	±0.20	18.25	±0.25	5.900	±0.10
40.00	40.545	±0.225	19.75	±0.25	6.400	±0.10
42.00	42.545	±0.225	19.25	±0.25	6.400	±0.10
44.00	44.545	±0.225	20.75	±0.25	6.900	±0.10
45.00	45.545	±0.225	20.75	±0.25	6.900	±0.10
50.00	50.635	±0.265	22.75	±0.25	6.900	±0.10
52.00	52.635	±0.265	23.50	±0.25	6.900	±0.10

Codification code example: 46000- 4.0 CTM17-BC

Hammer drill tips – ANSI 46600

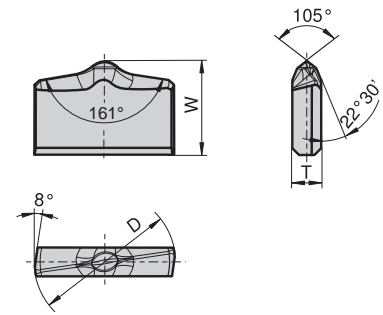

Ø [inch]	D [mm]	Tol. [mm]	W [mm]	Tol. [mm]	T [mm]	Tol. [mm]
1/8"	3.485	±0.075	4.00	±0.10	0.950	±0.050
5/32"	4.265	±0.075	4.15	±0.10	0.950	±0.050
11/64"	4.675	±0.075	4.65	±0.10	1.150	±0.050
3/16"	5.130	±0.10	4.65	±0.10	1.150	±0.050
13/64"	5.510	±0.10	5.25	±0.10	1.150	±0.050
7/32"	5.920	±0.10	5.30	±0.10	1.350	±0.050
15/64"	6.300	±0.10	5.30	±0.10	1.550	±0.050
1/4"	6.710	±0.10	5.30	±0.10	1.550	±0.050
17/64"	7.110	±0.10	6.15	±0.10	1.550	±0.050
9/32"	7.620	±0.10	6.15	±0.10	1.550	±0.050
5/16"	8.410	±0.10	6.45	±0.10	1.950	±0.050
3/8"	10.010	±0.10	6.85	±0.10	2.125	±0.075
7/16"	11.765	±0.125	7.70	±0.10	2.125	±0.075
1/2"	13.335	±0.125	8.70	±0.10	2.725	±0.075
9/16"	14.915	±0.125	9.10	±0.10	2.925	±0.075
5/8"	16.635	±0.125	9.40	±0.10	2.925	±0.075
11/16"	18.235	±0.125	9.65	±0.10	3.400	±0.100
3/4"	19.840	±0.150	11.55	±0.10	3.400	±0.100
13/16"	21.410	±0.150	11.55	±0.10	3.400	±0.100
27/32"	22.230	±0.150	12.15	±0.10	3.900	±0.100
7/8"	23.140	±0.150	12.15	±0.10	3.900	±0.100
15/16"	24.740	±0.150	13.25	±0.10	4.400	±0.100
1"	26.320	±0.150	13.25	±0.10	4.400	±0.100
1 1/16"	28.080	±0.190	14.70	±0.10	4.900	±0.100
1 1/8"	29.660	±0.190	14.70	±0.10	4.900	±0.100
1 1/4"	32.830	±0.190	16.80	±0.10	5.400	±0.100
1 5/16"	34.530	±0.190	16.80	±0.10	5.400	±0.100
1 3/8"	36.010	±0.190	16.80	±0.10	5.400	±0.100
1 7/16"	37.580	±0.190	17.35	±0.10	5.900	±0.100
1 1/2"	39.180	±0.190	17.35	±0.10	5.900	±0.100
1 9/16"	40.585	±0.255	19.75	±0.10	6.400	±0.100
1 3/4"	45.265	±0.255	20.75	±0.10	6.900	±0.100
2"	51.815	±0.255	23.50	±0.25	6.900	±0.100

Codification code example: 46600- 1/8" CTM17-BC

Hammer drill tips – JAPAN

47500

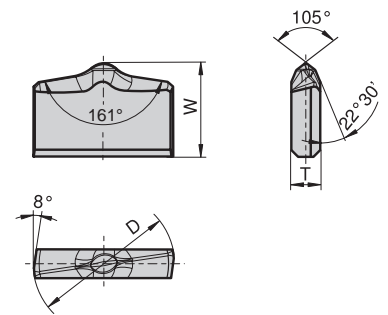

\varnothing [mm]	D [mm]	Tol. [mm]	W [mm]	Tol. [mm]	T [mm]	Tol. [mm]
3.4	3.500	±0.10	3.75	±0.10	0.950	±0.05
3.5	3.520	±0.10	3.75	±0.10	0.950	±0.05
3.8	3.900	±0.10	3.75	±0.10	0.950	±0.05
4.0	4.100	±0.10	3.95	±0.10	0.950	±0.05
4.3	4.400	±0.10	4.15	±0.10	0.950	±0.05
4.8	4.900	±0.10	4.45	±0.10	0.950	±0.05
5.0	5.100	±0.10	4.65	±0.10	1.150	±0.05
5.3	5.400	±0.10	4.65	±0.10	1.150	±0.05
5.4	5.500	±0.10	4.95	±0.10	1.350	±0.05
6.0	6.100	±0.10	4.85	±0.10	1.350	±0.05
6.4	6.525	±0.125	5.15	±0.10	1.350	±0.05
7.0	7.125	±0.125	5.35	±0.10	1.550	±0.05
8.0	8.125	±0.125	5.95	±0.15	1.950	±0.05
9.0	9.125	±0.125	6.30	±0.15	1.925	±0.075
9.5	9.625	±0.125	6.30	±0.15	1.925	±0.075
10.0	10.125	±0.125	6.85	±0.15	2.125	±0.075
10.5	10.650	±0.15	7.30	±0.15	2.125	±0.075
11.0	11.150	±0.15	7.70	±0.15	2.125	±0.075
12.0	12.150	±0.15	8.25	±0.15	2.425	±0.075
12.5	12.650	±0.15	8.25	±0.15	2.425	±0.075
12.7	12.850	±0.15	8.25	±0.15	2.425	±0.075
13.5	13.650	±0.15	8.70	±0.15	2.725	±0.075
14.3	14.450	±0.15	8.95	±0.15	2.925	±0.075
14.5	14.650	±0.15	8.95	±0.15	2.925	±0.075
15.0	15.150	±0.15	9.35	±0.25	2.925	±0.075
16.0	16.150	±0.15	9.35	±0.25	2.925	±0.075
16.5	16.650	±0.15	9.35	±0.25	2.925	±0.075
17.0	17.150	±0.15	9.35	±0.25	2.925	±0.075
17.5	17.650	±0.15	9.35	±0.25	2.925	±0.075
18.0	18.175	±0.175	9.65	±0.25	3.400	±0.10
19.0	19.175	±0.175	10.40	±0.25	3.400	±0.10
20.0	20.175	±0.175	11.25	±0.25	3.400	±0.10
21.5	21.675	±0.175	12.15	±0.25	3.900	±0.10
22.0	22.175	±0.175	12.30	±0.25	3.900	±0.10

Codification code example: 47500- 3.4 CTM17-BC

Hammer drill tips – METRIC 50850

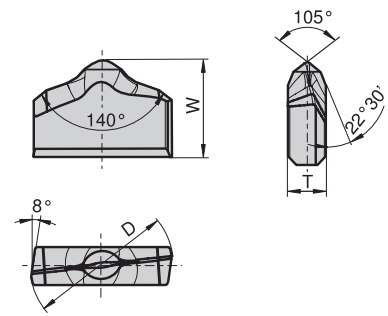

Ø [mm]	D [mm]	Tol. [mm]	W [mm]	Tol. [mm]	T [mm]	Tol. [mm]
4.0	4.285	±0.075	3.60	±0.10	1.350	±0.05
5.0	5.285	±0.075	4.10	±0.10	1.550	±0.05
5.5	5.785	±0.075	4.50	±0.10	1.550	±0.05
6.0	6.285	±0.075	4.90	±0.10	1.750	±0.05
6.5	6.785	±0.075	5.30	±0.10	1.750	±0.05
7.0	7.285	±0.075	5.70	±0.15	1.950	±0.05
8.0	8.285	±0.075	5.75	±0.15	2.250	±0.05
10.0	10.300	±0.090	7.15	±0.15	2.425	±0.075
12.0	12.340	±0.090	8.55	±0.15	2.725	±0.075
20.0	20.430	±0.120	12.25	±0.25	3.900	±0.100

Codification code example: 50850- 4.0 CTM17-BC

Hammer drill tips – ANSI 50850

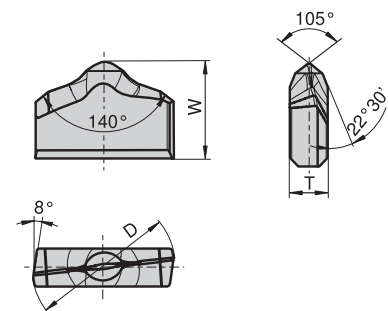

Ø [mm]	D [mm]	Tol. [mm]	W [mm]	Tol. [mm]	T [mm]	Tol. [mm]
5/32"	4.265	±0.075	3.60	±0.10	1.350	±0.05
3/16"	5.130	±0.100	4.10	±0.10	1.550	±0.05
7/32"	5.920	±0.100	4.50	±0.10	1.550	±0.05
5/16"	8.410	±0.100	5.75	±0.15	2.250	±0.05

Codification code example: 50850- 5/32" CTM17-BC

Hammer drill tips – METRIC

11384

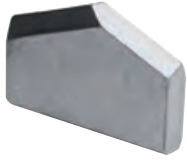

Conforming to PGM

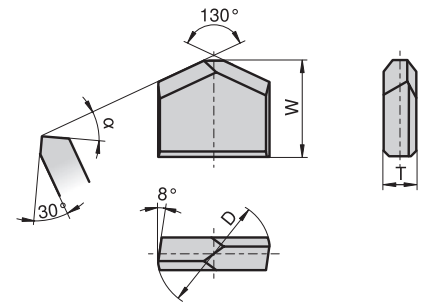

Ø [mm]	D [mm]	Tol. [mm]	W [mm]	Tol. [mm]	T [mm]	Tol. [mm]	α
4.0	4.21	+0.15	4.5	+0.20	1.0	-0.10	20°
5.0	5.21	+0.15	5.0	+0.20	1.2	-0.10	20°
5.5	5.71	+0.15	5.3	+0.20	1.4	-0.10	20°
6.0	6.21	+0.15	5.3	+0.20	1.4	-0.10	20°
6.5	6.65	+0.15	5.8	+0.20	1.4	-0.10	20°
7.0	7.21	+0.15	5.8	+0.20	1.6	-0.10	20°
8.0	8.21	+0.15	6.5	+0.30	2.0	-0.10	20°
8.5	8.65	+0.18	6.9	+0.30	2.0	-0.10	20°
9.0	9.21	+0.18	6.9	+0.30	2.0	-0.15	20°
10.0	10.21	+0.18	7.5	+0.30	2.2	-0.15	20°
10.5	10.71	+0.18	8.0	+0.30	2.2	-0.15	20°
11.0	11.25	+0.18	8.5	+0.30	2.2	-0.15	20°
12.0	12.25	+0.18	9.0	+0.30	2.5	-0.15	20°
13.0	13.25	+0.21	9.5	+0.30	2.8	-0.15	30°
14.0	14.25	+0.21	9.8	+0.30	3.0	-0.15	30°
15.0	15.25	+0.21	10.5	+0.50	3.0	-0.15	30°
16.0	16.25	+0.21	10.5	+0.50	3.0	-0.15	30°
17.0	17.25	+0.21	10.5	+0.50	3.0	-0.15	30°
18.0	18.25	+0.21	11.0	+0.50	3.5	-0.20	30°
19.0	19.31	+0.24	12.0	+0.50	3.5	-0.20	30°
20.0	20.31	+0.24	13.0	+0.50	3.5	-0.20	30°
22.0	22.26	+0.24	14.0	+0.50	4.0	-0.20	30°
23.0	23.26	+0.24	14.0	+0.50	4.0	-0.20	30°
24.0	24.26	+0.24	15.0	+0.50	4.5	-0.20	30°
25.0	25.26	+0.24	15.0	+0.50	4.5	-0.20	30°
26.0	26.26	+0.24	15.0	+0.50	4.5	-0.20	30°
28.0	28.26	+0.24	17.0	+0.50	5.0	-0.20	30°
29.0	29.26	+0.24	17.0	+0.50	5.0	-0.20	30°
30.0	30.26	+0.24	17.0	+0.50	5.0	-0.20	30°
32.0	32.37	+0.30	19.0	+0.50	5.5	-0.20	30°
35.0	35.37	+0.30	20.5	+0.50	6.0	-0.20	30°
36.0	36.37	+0.30	21.0	+0.50	6.0	-0.20	30°
37.0	37.27	+0.40	21.0	+0.50	6.0	-0.20	30°
38.0	38.37	+0.40	21.0	+0.50	6.0	-0.20	30°
40.0	40.32	+0.45	23.0	+0.50	6.5	-0.20	30°
42.0	42.32	+0.45	24.0	+0.50	6.5	-0.20	30°
44.0	44.32	+0.45	24.0	+0.50	7.0	-0.20	30°
45.0	45.32	+0.45	24.5	+0.50	7.0	-0.20	30°
50.0	50.37	+0.55	26.0	+0.50	7.0	-0.20	30°
52.0	52.37	+0.55	26.0	+0.50	7.0	-0.20	30°

Codification code example: 11384- 4.0 CTM17-BC

Hammer drill tips – ANSI 17871 Inch

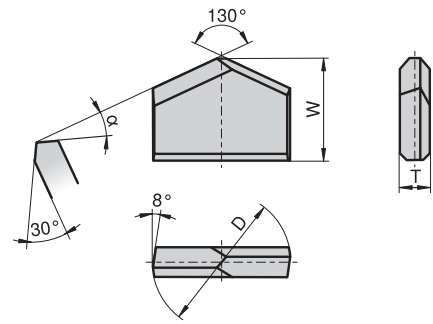

Ø [inch]	ANSI code	D [inch]	Tol. [inch]	W [inch]	Tol. [inch]	T [inch]	Tol. [inch]	α
1/8"	HDG 2	0.140	-0.006	0.165	+0.010	0.035	-0.004	20°
5/32"	HDG 2.5	0.171	-0.006	0.177	+0.008	0.039	-0.004	20°
11/64"	HDG 2.75	0.187	-0.006	0.197	+0.008	0.047	-0.004	20°
3/16"	HDG 3	0.206	-0.008	0.197	+0.008	0.047	-0.004	20°
13/64"	HDG 3.25	0.221	-0.008	0.220	+0.008	0.047	-0.004	20°
7/32"	HDG 3.5	0.237	-0.008	0.220	+0.008	0.055	-0.004	20°
15/64"	HDG 3.75	0.252	-0.008	0.220	+0.008	0.055	-0.004	20°
1/4"	HDG 4	0.268	-0.008	0.220	+0.008	0.055	-0.004	20°
17/64"	HDG 4.24	2.877	-0.008	0.256	+0.008	0.063	-0.004	20°
9/32"	HDG 4.5	0.304	-0.008	0.256	+0.008	0.063	-0.004	20°
5/16"	HDG 5	0.335	-0.008	0.256	+0.008	0.078	-0.004	20°
3/8"	HDG 6	0.398	-0.008	0.295	+0.008	0.086	-0.006	20°
7/16"	HDG 7	0.468	-0.010	0.334	+0.008	0.086	-0.006	20°
1/2"	HDG 8	0.530	-0.010	0.374	+0.008	0.110	-0.006	30°
9/16"	HDG 9	0.592	-0.010	0.374	+0.008	0.118	-0.006	30°
5/8"	HDG 10	0.660	-0.010	0.413	+0.008	0.118	-0.006	30°
11/16"	HDG 11	0.723	-0.010	0.433	+0.008	0.137	-0.008	30°
3/4"	HDG 12	0.787	-0.012	0.512	+0.008	0.137	-0.008	30°
13/16"	HDG 13	0.849	-0.012	0.512	+0.008	0.137	-0.008	30°
27/32"	HDG 13.5	0.881	-0.012	0.551	+0.008	0.157	-0.008	30°
7/8"	HDG 14	0.917	-0.012	0.551	+0.008	0.157	-0.008	30°
15/16"	HDG 15	0.980	-0.012	0.590	+0.008	0.177	-0.008	30°
1"	HDG 16	1.042	-0.012	0.590	+0.008	0.177	-0.008	30°
1 1/8"	HDG 18	1.175	-0.015	0.669	+0.008	0.196	-0.008	30°
1 1/4"	HDG 20	1.300	-0.015	0.748	+0.008	0.216	-0.008	30°
1 3/8"	HDG 22	1.425	-0.015	0.748	+0.008	0.216	-0.008	30°
1 1/2"	HDG 24	1.550	-0.015	0.827	+0.008	0.236	-0.008	30°
2"	–	2.050	-0.020	1.024	+0.020	0.276	-0.008	30°

Codification code example: 17871- 1/8" CTM17-BC

Hammer drill tips – ANSI 17871

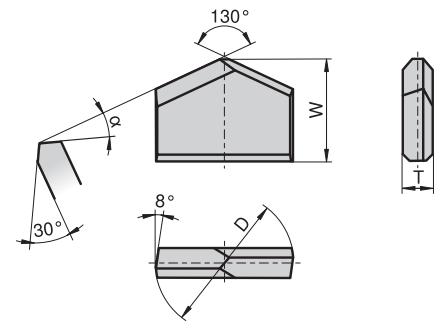

Ø [inch]	ANSI code	D [mm]	Tol. [mm]	W [mm]	Tol. [mm]	T [mm]	Tol. [mm]	α
1/8"	HDG 2	3.55	-0.15	4.16	+0.25	0.9	-0.10	20°
5/32"	HDG 2.5	4.34	-0.15	4.50	+0.20	1.0	-0.10	20°
11/64"	HDG 2.75	4.75	-0.15	5.00	+0.20	1.2	-0.10	20°
3/16"	HDG 3	5.23	-0.20	5.00	+0.20	1.2	-0.10	20°
13/64"	HDG 3.25	5.61	-0.20	5.60	+0.20	1.2	-0.10	20°
7/32"	HDG 3.5	6.02	-0.20	5.60	+0.20	1.4	-0.10	20°
15/64"	HDG 3.75	6.40	-0.20	5.60	+0.20	1.4	-0.10	20°
1/4"	HDG 4	6.81	-0.20	5.60	+0.20	1.4	-0.10	20°
17/64"	HDG 4.24	7.31	-0.20	6.60	+0.10	1.6	-0.10	20°
9/32"	HDG 4.5	7.72	-0.20	6.60	+0.20	1.6	-0.10	20°
5/16"	HDG 5	8.51	-0.20	6.60	+0.20	2.0	-0.10	20°
3/8"	HDG 6	10.11	-0.20	7.50	+0.20	2.2	-0.15	20°
7/16"	HDG 7	11.89	-0.25	8.50	+0.20	2.2	-0.15	20°
1/2"	HDG 8	13.46	-0.25	9.50	+0.20	2.8	-0.15	30°
9/16"	HDG 9	15.04	-0.25	9.50	+0.20	3.0	-0.15	30°
5/8"	HDG 10	16.76	-0.25	10.50	+0.20	3.0	-0.15	30°
11/16"	HDG 11	18.36	-0.25	11.00	+0.20	3.5	-0.20	30°
3/4"	HDG 12	19.99	-0.30	13.00	+0.20	3.5	-0.20	30°
13/16"	HDG 13	21.50	-0.30	13.00	+0.20	3.5	-0.20	30°
27/32"	HDG 13.5	22.38	-0.30	14.00	+0.20	4.0	-0.20	30°
7/8"	HDG 14	23.29	-0.30	14.00	+0.20	4.0	-0.20	30°
15/16"	HDG 15	24.89	-0.30	15.00	+0.20	4.5	-0.20	30°
1"	HDG 16	26.47	-0.30	15.00	+0.20	4.5	-0.20	30°
1 1/8"	HDG 18	29.85	-0.38	17.00	+0.20	5.0	-0.20	30°
1 1/4"	HDG 20	33.02	-0.38	19.00	+0.20	5.5	-0.20	30°
1 3/8"	HDG 22	36.20	-0.38	19.00	+0.20	5.5	-0.20	30°
1 1/2"	HDG 24	39.37	-0.38	21.00	+0.20	6.0	-0.20	30°
2"	–	52.07	-0.51	26.00	+0.50	7.0	-0.20	30°

Codification code example: 17871- 1/8" CTM17-BC

Hammer drill tips – JAPAN 26000

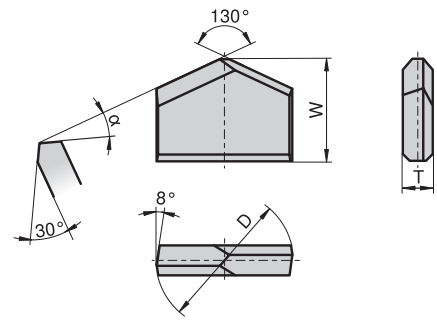
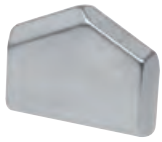

Ø [mm]	D [mm]	Tol. [mm]	W [mm]	Tol. [mm]	T [mm]	Tol. [mm]	α
4.0	4.0	+0.20	4.2	+0.20	1.0	-0.10	20°
4.3	4.3	+0.20	4.5	+0.20	1.0	-0.10	20°
4.8	4.8	+0.20	4.8	+0.20	1.0	-0.10	20°
5.0	5.0	+0.20	5.0	+0.20	1.2	-0.10	20°
6.0	6.0	+0.20	5.3	+0.20	1.4	-0.10	20°
6.4	6.4	+0.25	5.6	+0.20	1.4	-0.10	20°
7.0	7.0	+0.25	5.8	+0.20	1.6	-0.10	20°
8.0	8.0	+0.25	6.5	+0.30	2.0	-0.10	20°
9.0	9.0	+0.25	6.9	+0.30	2.0	-0.15	20°
9.5	9.5	+0.25	6.9	+0.30	2.0	-0.15	20°
10.0	10.0	+0.25	7.5	+0.30	2.2	-0.15	20°
10.5	10.5	+0.30	8.0	+0.30	2.2	-0.15	20°
11.0	11.0	+0.30	8.5	+0.30	2.2	-0.15	20°
12.0	12.0	+0.30	9.0	+0.30	2.5	-0.15	20°
12.5	12.5	+0.30	9.0	+0.30	2.5	-0.15	20°
12.7	12.7	+0.30	9.0	+0.30	2.5	-0.15	20°
13.5	13.5	+0.30	9.5	+0.30	2.8	-0.15	30°
14.5	14.5	+0.30	9.8	+0.30	3.0	-0.15	30°
15.0	15.0	+0.30	10.5	+0.50	3.0	-0.15	30°
16.0	16.0	+0.30	10.5	+0.50	3.0	-0.15	30°
16.5	16.5	+0.30	10.5	+0.50	3.0	-0.15	30°
17.0	17.0	+0.30	10.5	+0.50	3.0	-0.15	30°
17.5	17.5	+0.30	10.5	+0.50	3.0	-0.15	30°
18.0	18.0	+0.35	11.0	+0.50	3.5	-0.20	30°
19.0	19.0	+0.35	12.0	+0.50	3.5	-0.20	30°
20.0	20.0	+0.35	13.0	+0.50	3.5	-0.20	30°
22.0	22.0	+0.35	14.0	+0.50	4.0	-0.20	30°

Codification code example: 26000- 4.0 CTM17-BC

Hammer drill tips – METRIC

14444

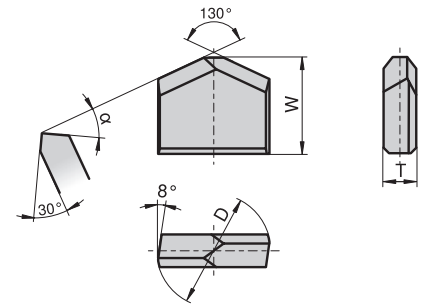

Ø [mm]	D [mm]	Tol. [mm]	W [mm]	Tol. [mm]	T [mm]	Tol. [mm]	α
4.0	4.20	+0.10	5.0	+0.20	1.4	-0.10	30°
5.0	5.21	+0.15	5.0	+0.20	1.6	-0.10	30°
5.5	5.71	+0.15	5.3	+0.20	1.8	-0.10	30°
6.0	6.21	+0.15	5.3	+0.20	1.8	-0.10	30°
6.5	6.71	+0.15	5.8	+0.20	1.8	-0.10	30°
7.0	7.21	+0.15	6.0	+0.20	2.0	-0.10	30°
8.0	8.21	+0.15	6.5	+0.30	2.3	-0.10	30°

Codification code example: 14444- 4.0 CTM17-BC

38500



Ø [mm]	D [mm]	Tol. [mm]	W [mm]	Tol. [mm]	T [mm]	Tol. [mm]	α
3.0	3.15	+0.10	3.5	+0.20	0.8	-0.10	30°
3.5	3.65	+0.15	3.5	+0.20	1.2	-0.10	30°
4.5	4.65	+0.15	5.0	+0.20	1.4	-0.10	30°

Codification code example: 38500- 3.0 CTM17-BC

38911

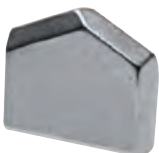

Ø [mm]	D [mm]	Tol. [mm]	W [mm]	Tol. [mm]	T [mm]	Tol. [mm]	α
4.00	4.30	+0.15	5.1	±0.10	1.2	-0.07	20°
5.00	5.20	+0.15	5.1	±0.10	1.4	-0.07	20°
6.00	6.25	+0.15	5.4	±0.10	1.6	-0.07	20°

Codification code example: 38911- 4.0 CTM17-BC

Hammer drill tips – METRIC

39742

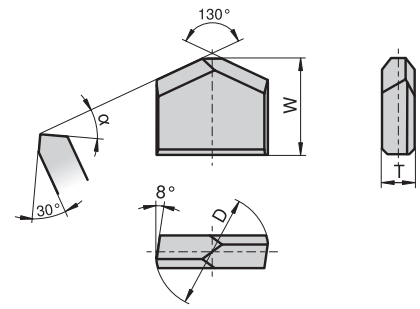

\emptyset [mm]	D [mm]	Tol. [mm]	W [mm]	Tol. [mm]	T [mm]	Tol. [mm]	α
3.5	3.5	+0.10	4.0	+0.25	0.8	-0.07	20°

Codification code example: 39742- 3.5 CTM17-BC

40429



\emptyset [mm]	D [mm]	Tol. [mm]	W [mm]	Tol. [mm]	T [mm]	Tol. [mm]	α
3.5	3.5	+0.10	3.5	+0.20	1.2	-0.10	30°

Codification code example: 40429- 3.5 CTM17-BC

Masonry drill tips

Schlagbohrerplatten

Plaquettes pour mèche maçonnerie

Placchette per punte a forare

Puntas de brocas para hormigon

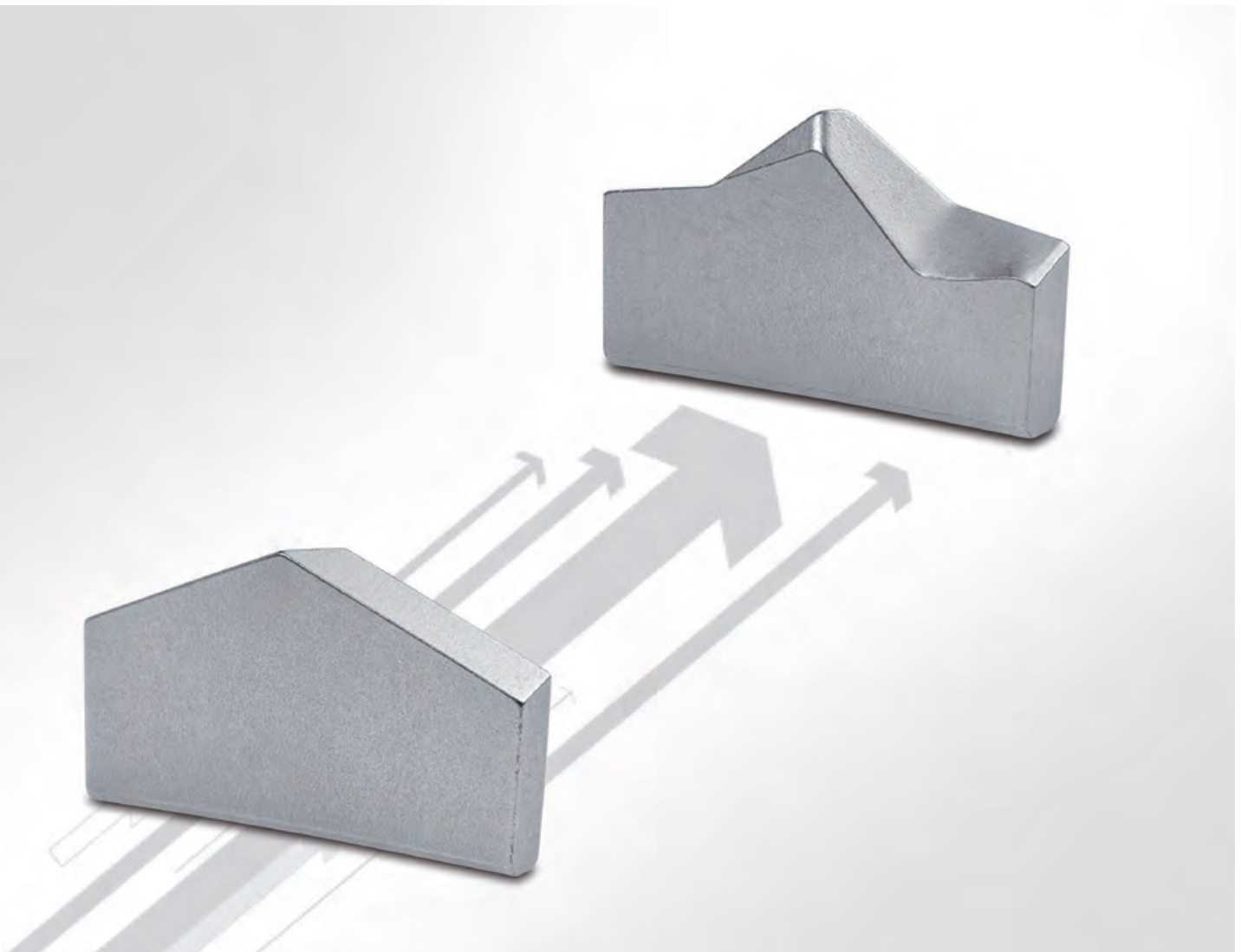

Index

Grades	Page
Composition and properties	38
Applications	39
CERATIZIT Style 58000	40

Premium Masonry Drill Tips	Style	Range Ø	Specificity	PGM Conformity	Page
58000	METRIC (Ø mm)	4 – 20		✓	41
58000	ANSI (Ø inch)	1/8" – 1"			42

Robust Masonry Drill Tips	Style	Range Ø	Specificity	PGM Conformity	Page
11400	METRIC (Ø mm)	3 – 35	130°	✓	43
46973	ANSI (Ø inch)	1/8" – 1"	130°		44
32222	METRIC (Ø mm)	3 – 10	Variant T		45
37071	METRIC (Ø mm)	3.4 – 3.5	130°		46

Speed Masonry Drill Tips	Style	Range Ø	Specificity	PGM Conformity	Page
12500	METRIC (Ø mm)	3 – 14	130°	✓	47
22000	ANSI (Ø inch)	1/8" – 1 1/2"	130°		48–49
16300	METRIC (Ø mm)	12 – 30	130°	✓	50
23500	METRIC (Ø mm)	3 – 20	120°	✓	51

Medium Masonry Drill Tips	Style	Range Ø	Specificity	PGM Conformity	Page
24323	METRIC (Ø mm)	4 – 16	130°	✓	52
43500	METRIC (Ø mm)	3 – 16	118°	✓	53

Eco Masonry Drill Tips	Style	Range Ø	Specificity	PGM Conformity	Page
16000	METRIC (Ø mm)	12 – 30	11400 Reduced T	✓	54
28500	ANSI (Ø inch)	1/8" – 1 1/2"	22000 Reduced W		55
46716	METRIC (Ø mm)	6 – 10	Reduced T & W		56

Accu Masonry Drill Tips	Style	Range Ø	Specificity	PGM Conformity	Page
50210	METRIC (Ø mm)	4 – 25	110°	✓	57

Grades for stone working – composition and properties

MASONRY	CERATIZIT grade code	ISO code	Grain	%Co	HV10	TRS
Small Diameter	CTF11-BC	BC03	F	5.6	1760	2300
Large Diameter	CTF12-BC	BC05	F	6.0	1640	2200
Special for low impact	CTF08-BC	BC01	F	4.0	1840	2200
Special for heavy duty	CTM14-BC	BC10	M	7.0	1550	2600

HAMMER	CERATIZIT grade code	ISO code	Grain	%Co	HV10	TRS
Small Diameter	CTM17-BC	BC20	M	8.5	1420	2900
Large Diameter	CTM17-BC	BC20	M	8.5	1420	2800
Special for low impact	CTM14-BC	BC10	M	7.0	1550	2600
Special for heavy duty	CTF24-BC	BC30	F	12.0	1330	3000

Classification of the WC grain size

Average grain size [µm]	Classification	CERATIZIT-code
< 0.2	nano	N
0.2 – < 0.5	ultrafine	U
0.5 – < 0.8	submicron	S
0.8 – < 1.3	fine	F
1.3 – < 2.5	medium	M
2.5 – < 6.0	coarse	C
> 6.0	extra-coarse	E

Applications



Type, description	METRIC	ANSI	PGM	Concrete	Stone	Bricks	Granit & Marble	Roofing tile	Tiles	Metal	Wood
58000	✓		✓	●	●	●	●	●			
58800		✓		●	●	●	●	●			
11400	✓		✓	●	●	●		○			
46973		✓		●	●	●		○			
32222	✓			○		●	●	●	●	●	●
37071	✓			●	●	●					
12500	✓		✓	○	●	●	●	●	●	●	●
22000		✓		○	●	●	●	●	●	●	●
16300	✓		✓	○	●	●	●	●	●	●	●
23500	✓		✓	○	●	●	●	●	●	●	●
24323	✓		✓	●	●	●		○	○		
43500	✓		✓	○	●	●	●	●	●	●	●
16000	✓		✓	●	●	●		○	○		
28500		✓		○		●	●	●	●	●	●
46716	✓			○		●	●	●	●	●	●
50210	✓		✓	●		●		○	○		

● Optimum
○ Not optimum

CERATIZIT Style 58000

Advantages of Style 58000

- ▲ Optimised CERATIZIT grade CTF12-BC with a hardness of 1640 HV10
- ▲ Especially well suited for cordless drills

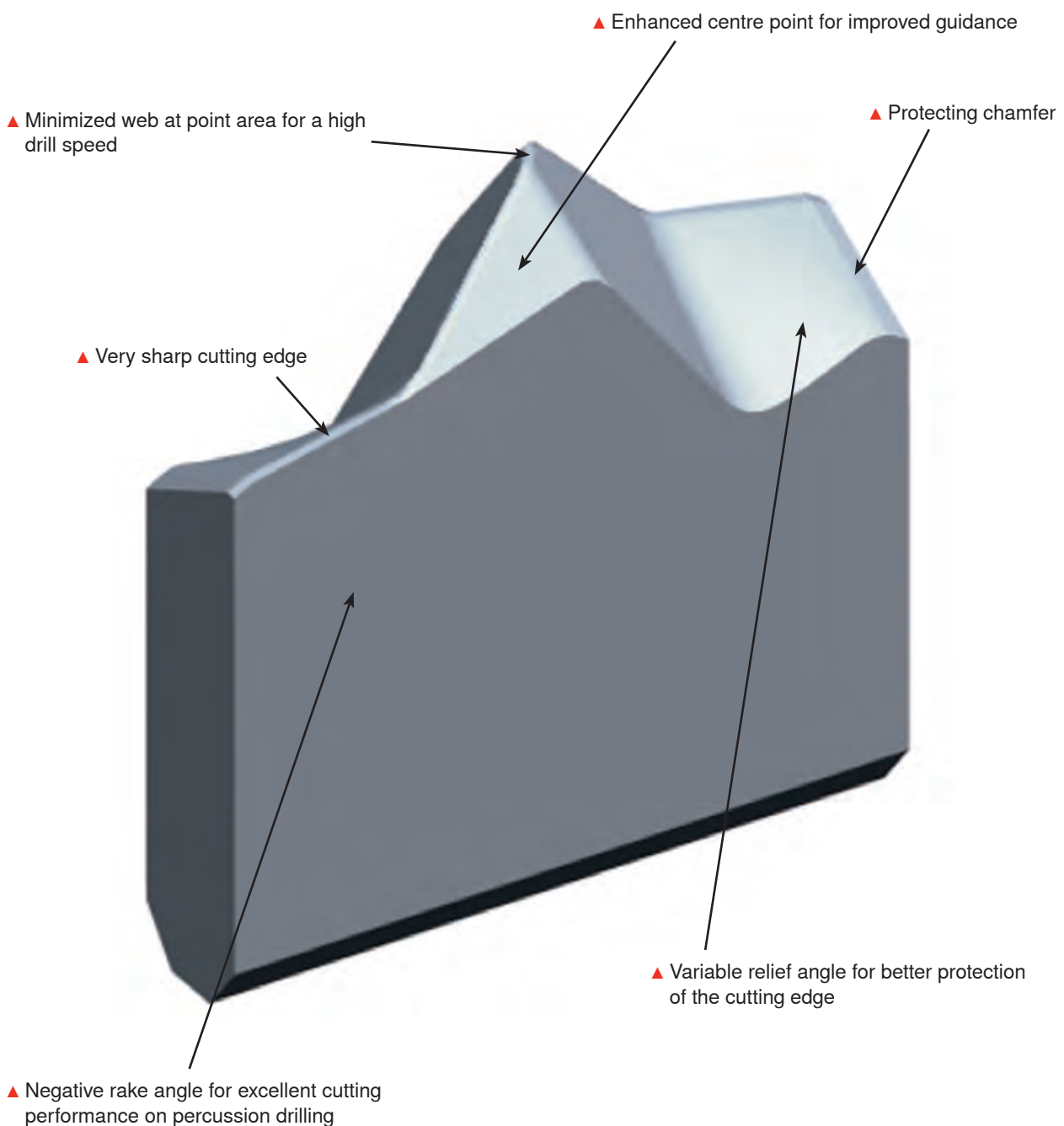

Masonry drill tips – METRIC 58000



Conforming to PGM

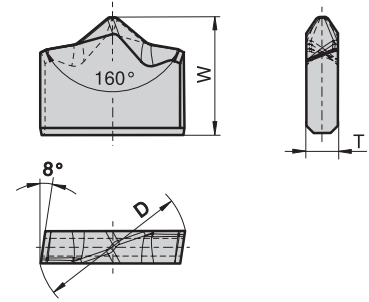

Ø [mm]	D [mm]	Tol. [mm]	W [mm]	Tol. [mm]	T [mm]	Tol. [mm]
4.0	4.18	+0.12	3.30	±0.10	1.00	-0.07
5.0	5.18	+0.12	4.15	±0.10	1.20	-0.07
5.5	5.68	+0.12	4.55	±0.10	1.20	-0.07
6.0	6.18	+0.12	4.95	±0.10	1.40	-0.10
6.5	6.68	+0.12	5.35	±0.10	1.40	-0.10
7.0	7.21	+0.15	5.75	±0.10	1.60	-0.10
8.0	8.21	+0.15	5.80	±0.15	1.80	-0.10
9.0	9.21	+0.15	6.50	±0.15	2.00	-0.10
10.0	10.21	+0.15	7.20	±0.15	2.20	-0.15
12.0	12.23	+0.20	8.60	±0.15	2.50	-0.15
13.0	13.23	+0.20	9.30	±0.15	2.50	-0.15
14.0	14.23	+0.20	10.00	±0.15	2.80	-0.18
16.0	16.23	+0.20	9.95	±0.25	2.80	-0.18
18.0	18.23	+0.20	11.15	±0.25	2.80	-0.18
20.0	20.24	+0.28	12.40	±0.25	3.00	-0.18

Codification code example: 58000- 4.0 CTF12-BC

Masonry drill tips – ANSI 58800

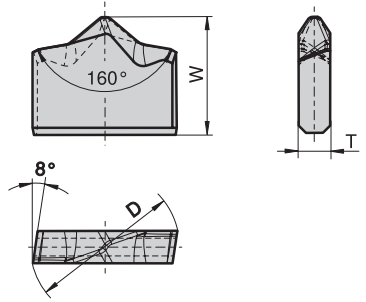

Ø [mm]	D [mm]	Tol. [mm]	W [mm]	Tol. [mm]	T [mm]	Tol. [mm]
1/8"	3.55	-0.15	2.70	±0.125	0.89	-0.07
5/32"	4.30	-0.12	3.30	±0.10	1.00	-0.07
3/16"	5.23	-0.20	4.00	±0.125	1.15	-0.07
7/32"	5.80	-0.12	4.55	±0.10	1.55	-0.07
1/4"	6.80	-0.20	5.30	±0.125	1.52	-0.07
5/16"	8.36	-0.15	5.80	±0.15	1.80	-0.10
3/8"	10.10	-0.20	6.85	±0.125	1.98	-0.07
7/16"	11.88	-0.25	8.05	±0.19	1.98	-0.07
5/8"	16.76	-0.25	9.90	±0.19	2.50	-0.15
3/4"	19.98	-0.30	11.80	±0.19	3.20	-0.18
7/8"	23.14	-0.30	13.20	±0.19	3.41	-0.12
1"	26.46	-0.30	14.40	±0.19	3.50	-0.18

Codification code example: 58800- 1/8" CTF12-BC

Masonry drill tips – METRIC 11400



Conforming to PGM

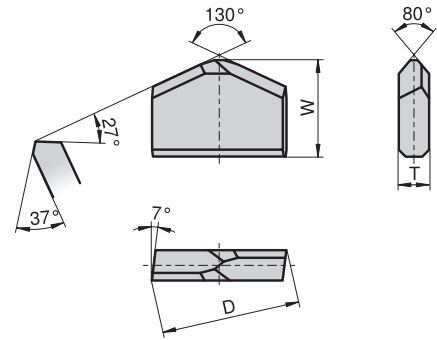

Ø [mm]	D [mm]	Tol. [mm]	W [mm]	Tol. [mm]	T [mm]	Tol. [mm]
3.0	3.0	+0.25 / +0.15	3.20	+0.20	0.8	-0.07
4.0	4.0	+0.30 / +0.18	3.20	+0.20	1.0	-0.07
4.5	4.5	+0.30 / +0.18	3.60	+0.20	1.0	-0.07
5.0	5.0	+0.30 / +0.18	4.00	+0.20	1.2	-0.07
5.5	5.5	+0.30 / +0.18	4.40	+0.20	1.2	-0.07
6.0	6.0	+0.30 / +0.18	4.80	+0.20	1.4	-0.10
6.5	6.5	+0.30 / +0.18	5.20	+0.20	1.4	-0.10
7.0	7.0	+0.36 / +0.21	5.60	+0.20	1.6	-0.10
7.5	7.5	+0.36 / +0.21	6.00	+0.30	1.6	-0.10
8.0	8.0	+0.36 / +0.21	5.60	+0.30	1.8	-0.10
9.0	9.0	+0.36 / +0.21	6.30	+0.30	2.0	-0.10
9.5	9.5	+0.36 / +0.21	6.70	+0.30	2.0	-0.10
10.0	10.0	+0.36 / +0.21	6.80	+0.30	2.2	-0.15
11.0	11.0	+0.43 / +0.23	7.70	+0.30	2.2	-0.15
12.0	12.0	+0.43 / +0.23	8.20	+0.30	2.5	-0.15
13.0	13.0	+0.43 / +0.23	8.90	+0.30	2.5	-0.15
14.0	14.0	+0.43 / +0.23	9.50	+0.30	2.8	-0.18
16.0	16.0	+0.43 / +0.23	9.60	+0.50	3.0	-0.18
18.0	18.0	+0.43 / +0.23	10.50	+0.50	3.0	-0.18
20.0	20.0	+0.52 / +0.24	11.65	+0.50	3.5	-0.20
22.0	22.0	+0.52 / +0.24	12.50	+0.50	3.5	-0.20
25.0	25.0	+0.52 / +0.24	13.80	+0.50	4.0	-0.20
28.0	28.0	+0.52 / +0.24	15.00	+0.50	4.5	-0.20
32.0	32.0	+0.52 / +0.24	17.00	+0.50	5.0	-0.20
35.0	35.0	+0.52 / +0.24	18.60	+0.50	5.5	-0.20

Codification code example: 11400- 3.0 CTF12-BC

Masonry drill tips – ANSI 46973

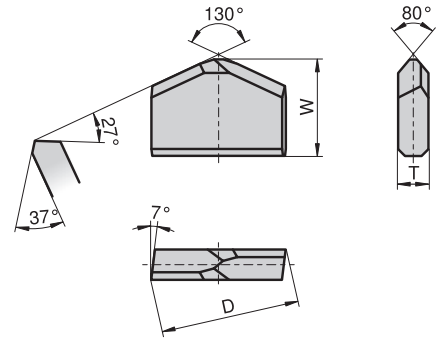

Ø [mm]	D [mm]	Tol. [mm]	W [mm]	Tol. [mm]	T [mm]	Tol. [mm]
1/8"	3.475	±0.075	4.285	±0.125	0.855	±0.035
3/16"	5.130	±0.100	5.125	±0.125	1.115	±0.035
5/16"	8.400	±0.100	6.725	±0.125	1.485	±0.035
3/8"	10.000	±0.100	8.245	±0.125	1.945	±0.035
7/16"	11.755	±0.125	9.710	±0.190	1.945	±0.035
5/8"	16.635	±0.125	13.140	±0.190	2.260	±0.050
3/4"	19.830	±0.150	15.370	±0.190	2.260	±0.050
7/8"	23.140	±0.150	16.700	±0.190	2.260	±0.050
1"	26.310	±0.150	18.420	±0.190	3.030	±0.050

Codification code example: 46973- 1/8" CTF12-BC

Masonry drill tips – METRIC 32222

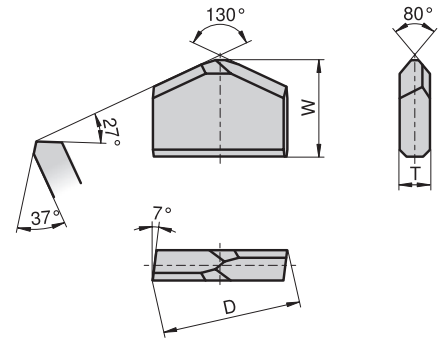
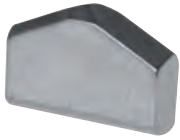

Ø [mm]	D [mm]	Tol. [mm]	W [mm]	Tol. [mm]	T [mm]	Tol. [mm]
3.0	3.0	+0.25 / +0.15	3.50	+0.20	0.80	-0.07
4.0	4.0	+0.30 / +0.18	3.30	+0.20	1.00	-0.07
5.0	5.0	+0.30 / +0.18	4.20	+0.20	1.20	-0.07
6.0	6.0	+0.30 / +0.18	4.70	+0.20	1.40	-0.10
6.5	6.5	+0.30 / +0.18	4.85	+0.20	1.40	-0.10
7.0	7.0	+0.36 / +0.21	5.15	+0.20	1.60	-0.10
8.0	8.0	+0.36 / +0.21	5.65	+0.30	1.80	-0.10
10.0	10.0	+0.36 / +0.21	6.55	+0.30	2.20	-0.15

Codification code example: 32222- 3.0 CTF12-BC

Masonry drill tips – METRIC 37071

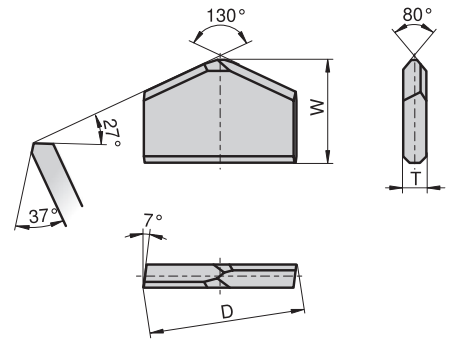

\emptyset [mm]	D [mm]	Tol. [mm]	W [mm]	Tol. [mm]	T [mm]	Tol. [mm]	α	β	γ
3.4	3.40	+0.15 / +0.05	4.16	+0.25	0.89	-0.07	20°	30°	9°
3.5	3.50	+0 / +0.20	4.20	+0.25	1.00	-0.10	20°	30°	9°

Codification code example: 37071- 3.40 CTF12-BC

Masonry drill tips – METRIC 12500

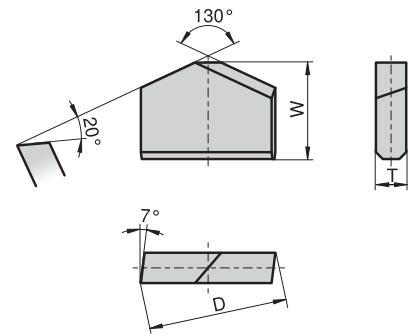
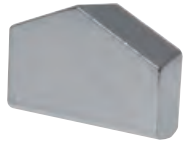

Ø [mm]	D [mm]	Tol. [mm]	W [mm]	Tol. [mm]	T [mm]	Tol. [mm]
3.0	3.0	+0.25 / +0.15	3.2	+0.20	0.8	-0.07
3.5	3.5	+0.25 / +0.15	3.6	+0.20	1.0	-0.07
4.0	4.0	+0.30 / +0.18	3.2	+0.20	1.0	-0.07
4.5	4.5	+0.30 / +0.18	3.6	+0.20	1.0	-0.07
5.0	5.0	+0.30 / +0.18	4.0	+0.20	1.2	-0.07
5.5	5.5	+0.30 / +0.18	4.4	+0.20	1.2	-0.07
6.0	6.0	+0.30 / +0.18	4.8	+0.20	1.4	-0.10
6.5	6.5	+0.30 / +0.18	5.2	+0.20	1.4	-0.10
7.0	7.0	+0.36 / +0.21	5.6	+0.20	1.6	-0.10
7.5	7.5	+0.36 / +0.21	6.0	+0.20	1.6	-0.10
8.0	8.0	+0.36 / +0.21	5.6	+0.30	1.8	-0.10
9.0	9.0	+0.36 / +0.21	6.3	+0.30	2.0	-0.10
9.5	9.5	+0.36 / +0.21	6.7	+0.30	2.0	-0.10
10.0	10.0	+0.36 / +0.21	6.7	+0.30	2.2	-0.15
11.0	11.0	+0.43 / +0.23	7.7	+0.30	2.2	-0.15
12.0	12.0	+0.43 / +0.23	8.2	+0.30	2.5	-0.15
13.0	13.0	+0.43 / +0.23	8.7	+0.30	2.5	-0.15
14.0	14.0	+0.43 / +0.23	9.3	+0.30	2.8	-0.18

Codification code example: 12500- 3.0 CTF12-BC

Masonry drill tips – ANSI 22000 Inch

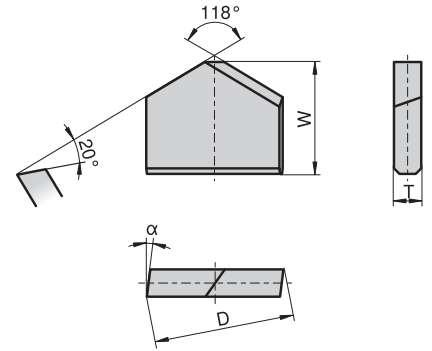

Ø [inch]	ANSI code	D [inch]	Tol. [inch]	W [inch]	Tol. [inch]	T [inch]	Tol. [inch]	α
1/8"	MDG 2	0.140	-0.006	0.164	+0.010	0.035	-0.003	9°
5/32"	MDG 2.5	0.171	-0.006	0.180	+0.010	0.035	-0.003	9°
3/16"	MDG 3	0.206	-0.008	0.197	+0.010	0.045	-0.003	8°
7/32"	MDG 3.5	0.237	-0.008	0.220	+0.010	0.045	-0.003	8°
1/4"	MDG 4	0.268	-0.008	0.220	+0.010	0.060	-0.003	8°
9/32"	MDG 4.5	0.304	-0.008	0.260	+0.010	0.060	-0.003	7°
5/16"	MDG 5	0.335	-0.008	0.260	+0.010	0.060	-0.003	7°
3/8"	MDG 6	0.398	-0.008	0.320	+0.010	0.078	-0.003	7°
7/16"	MDG 7	0.468	-0.010	0.375	+0.015	0.078	-0.003	7°
1/2"	MDG 8	0.530	-0.010	0.430	+0.015	0.091	-0.004	7°
9/16"	MDG 9	0.592	-0.010	0.472	+0.015	0.091	-0.004	7°
5/8"	MDG 10	0.660	-0.010	0.510	+0.015	0.091	-0.004	7°
3/4"	MDG 12	0.787	-0.012	0.598	+0.015	0.091	-0.004	7°
7/8"	MDG 14	0.917	-0.012	0.650	+0.015	0.091	-0.004	7°
1"	MDG 16	1.042	-0.012	0.718	+0.015	0.122	-0.005	7°
1 1/8"	MDG 18	1.175	-0.018	0.758	+0.020	0.122	-0.008	7°
1 1/4"	MDG 20	1.300	-0.018	0.758	+0.020	0.122	-0.008	7°
1 3/8"	MDG 22	1.425	-0.018	0.843	+0.020	0.122	-0.008	7°
1 1/2"	MDG 24	1.550	-0.018	0.843	+0.020	0.122	-0.008	7°

Codification code example: 22000- 1/8" CTF12-BC

Masonry drill tips – ANSI 22000

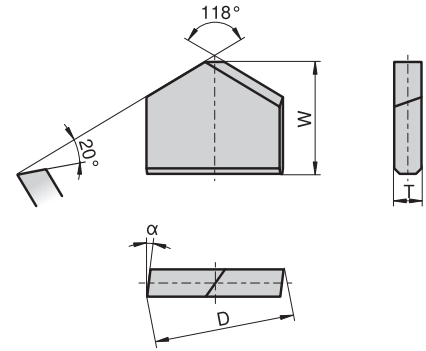

Ø [inch]	ANSI code	D [mm]	Tol. [mm]	W [mm]	Tol. [mm]	T [mm]	Tol. [mm]	α
1/8"	MDG 2	3.55	-0.15	4.16	+0.25	0.89	-0.07	9°
5/32"	MDG 2.5	4.34	-0.15	4.57	+0.25	0.89	-0.07	9°
3/16"	MDG 3	5.23	-0.20	5.00	+0.25	1.15	-0.07	8°
7/32"	MDG 3.5	6.01	-0.20	5.58	+0.25	1.15	-0.07	8°
1/4"	MDG 4	6.80	-0.20	5.58	+0.25	1.52	-0.07	8°
9/32"	MDG 4.5	7.72	-0.20	6.60	+0.25	1.52	-0.07	7°
5/16"	MDG 5	8.50	-0.20	6.60	+0.25	1.52	-0.07	7°
3/8"	MDG 6	10.10	-0.20	8.12	+0.25	1.98	-0.07	7°
7/16"	MDG 7	11.88	-0.25	9.52	+0.38	1.98	-0.07	7°
1/2"	MDG 8	13.46	-0.25	10.92	+0.38	2.31	-0.10	7°
9/16"	MDG 9	15.03	-0.25	11.98	+0.38	2.31	-0.10	7°
5/8"	MDG 10	16.76	-0.25	12.95	+0.38	2.31	-0.10	7°
3/4"	MDG 12	19.98	-0.30	15.18	+0.38	2.31	-0.10	7°
7/8"	MDG 14	23.29	-0.30	16.51	+0.38	2.31	-0.10	7°
1"	MDG 16	26.46	-0.30	18.23	+0.38	3.09	-0.12	7°
1 1/8"	MDG 18	29.84	-0.45	19.25	+0.50	3.09	-0.20	7°
1 1/4"	MDG 20	33.02	-0.45	19.25	+0.50	3.09	-0.20	7°
1 3/8"	MDG 22	36.19	-0.45	21.41	+0.50	3.09	-0.20	7°
1 1/2"	MDG 24	39.37	-0.45	21.41	+0.50	3.09	-0.20	7°

Codification code example: 22000- 1/8" CTF12-BC

Masonry drill tips – METRIC 16300

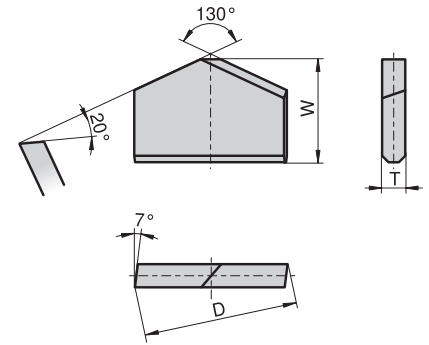
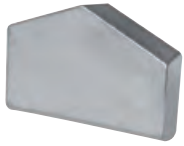

Ø [mm]	D [mm]	Tol. [mm]	W [mm]	Tol. [mm]	T [mm]	Tol. [mm]
12.0	12.0	+0.43 / +0.23	8.0	+0.30	1.8	-0.15
13.0	13.0	+0.43 / +0.23	8.7	+0.30	2.0	-0.15
14.0	14.0	+0.43 / +0.23	9.3	+0.30	2.1	-0.18
15.0	15.0	+0.43 / +0.23	9.6	+0.30	2.2	-0.18
16.0	16.0	+0.43 / +0.23	9.6	+0.50	2.2	-0.18
17.0	17.0	+0.43 / +0.23	10.5	+0.50	2.2	-0.18
18.0	18.0	+0.43 / +0.23	10.5	+0.50	2.2	-0.18
19.0	19.0	+0.43 / +0.23	11.5	+0.50	2.5	-0.18
20.0	20.0	+0.52 / +0.24	11.5	+0.50	2.5	-0.20
22.0	22.0	+0.52 / +0.24	12.5	+0.50	2.5	-0.20
24.0	24.0	+0.52 / +0.24	15.0	+0.50	3.0	-0.20
25.0	25.0	+0.52 / +0.24	15.0	+0.50	3.0	-0.20
26.0	26.0	+0.52 / +0.24	15.0	+0.50	3.0	-0.20
30.0	30.0	+0.52 / +0.24	16.0	+0.50	4.0	-0.20

Codification code example: 16300- 12.0 CTM17-BC

Masonry drill tips – METRIC 23500

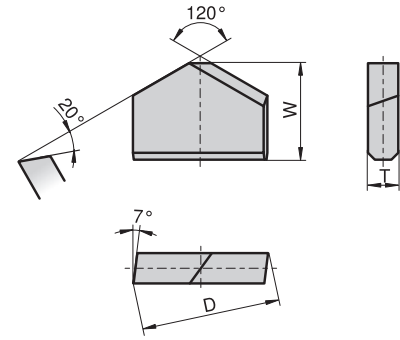

Ø [mm]	D [mm]	Tol. [mm]	W [mm]	Tol. [mm]	T [mm]	Tol. [mm]
3.0	3.0	+0.25 / +0.15	3.2	+0.20	0.8	-0.07
3.5	3.5	+0.25 / +0.15	3.6	+0.20	1.0	-0.07
4.0	4.0	+0.30 / +0.18	3.2	+0.20	1.0	-0.07
4.5	4.5	+0.30 / +0.18	3.6	+0.20	1.0	-0.07
5.0	5.0	+0.30 / +0.18	4.0	+0.20	1.2	-0.07
5.5	5.5	+0.30 / +0.18	4.4	+0.20	1.2	-0.07
6.0	6.0	+0.30 / +0.18	4.8	+0.20	1.4	-0.10
6.5	6.5	+0.30 / +0.18	5.2	+0.20	1.4	-0.10
7.0	7.0	+0.36 / +0.21	5.6	+0.20	1.6	-0.10
8.0	8.0	+0.36 / +0.21	5.6	+0.30	1.8	-0.10
9.0	9.0	+0.36 / +0.21	6.3	+0.30	2.0	-0.10
10.0	10.0	+0.36 / +0.21	7.0	+0.30	2.2	-0.15
11.0	11.0	+0.43 / +0.23	7.7	+0.30	2.2	-0.15
12.0	12.0	+0.43 / +0.23	8.4	+0.30	2.5	-0.15
13.0	13.0	+0.43 / +0.23	9.1	+0.30	2.5	-0.15
14.0	14.0	+0.43 / +0.23	9.3	+0.30	2.8	-0.18
16.0	16.0	+0.43 / +0.23	9.6	+0.50	3.0	-0.18
18.0	18.0	+0.43 / +0.23	10.50	+0.50	3.0	-0.18
20.0	20.0	+0.52 / +0.25	11.50	+0.50	3.5	-0.20

Codification code example: 23500- 3.0 CTF12-BC

Masonry drill tips – METRIC 24323

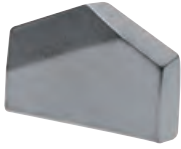

Conforming to PGM

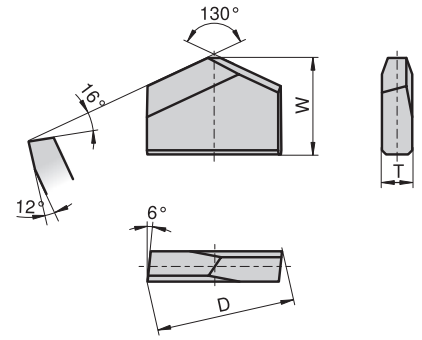

\varnothing [mm]	D [mm]	Tol. [mm]	W [mm]	Tol. [mm]	T [mm]	Tol. [mm]
4.0	4.0	+0.30 / +0.18	3.2	+0.20	1.0	-0.07
5.0	5.0	+0.30 / +0.18	4.0	+0.20	1.2	-0.07
5.5	5.5	+0.30 / +0.18	4.4	+0.20	1.2	-0.07
6.0	6.0	+0.30 / +0.18	4.8	+0.20	1.4	-0.10
6.5	6.5	+0.36 / +0.21	5.2	+0.20	1.4	-0.10
7.0	7.0	+0.36 / +0.21	5.6	+0.20	1.6	-0.10
8.0	8.0	+0.36 / +0.21	5.6	+0.30	1.8	-0.10
9.0	9.0	+0.36 / +0.21	6.3	+0.30	2.0	-0.10
10.0	10.0	+0.36 / +0.21	7.0	+0.30	2.2	-0.15
12.0	12.0	+0.43 / +0.23	8.4	+0.30	2.5	-0.15
14.0	14.0	+0.43 / +0.23	9.75	+0.30	2.8	-0.18
16.0	16.0	+0.43 / +0.23	9.6	+0.50	3.0	-0.18

Codification code example: 24323- 4.0 CTM14-BC

Masonry drill tips – METRIC 43500

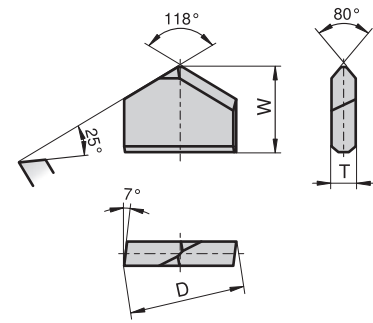
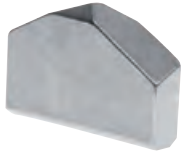

Ø [mm]	D [mm]	Tol. [mm]	W [mm]	Tol. [mm]	T [mm]	Tol. [mm]
3.0	3.0	+0.25 / +0.15	3.2	+0.20	0.8	-0.07
4.0	4.0	+0.30 / +0.18	3.2	+0.20	1.0	-0.07
5.0	5.0	+0.30 / +0.18	4.0	+0.20	1.2	-0.07
5.5	5.5	+0.30 / +0.18	4.4	+0.20	1.2	-0.07
6.0	6.0	+0.30 / +0.18	4.8	+0.20	1.4	-0.10
6.5	6.5	+0.30 / +0.18	5.2	+0.20	1.4	-0.10
7.0	7.0	+0.36 / +0.21	5.6	+0.20	1.6	-0.10
8.0	8.0	+0.36 / +0.21	5.6	+0.30	1.8	-0.10
9.0	9.0	+0.36 / +0.21	6.3	+0.30	2.0	-0.10
10.0	10.0	+0.36 / +0.21	7.0	+0.30	2.2	-0.15
11.0	11.0	+0.43 / +0.23	7.7	+0.30	2.2	-0.15
12.0	12.0	+0.43 / +0.23	8.4	+0.30	2.5	-0.15
14.0	14.0	+0.43 / +0.23	9.8	+0.30	2.1	-0.18
16.0	16.0	+0.43 / +0.23	9.8	+0.50	2.2	-0.18

Codification code example: 43500- 3.0 CTF11-BC

Masonry drill tips – METRIC 16000

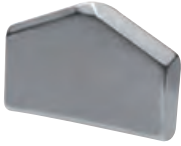

Conforming to PGM

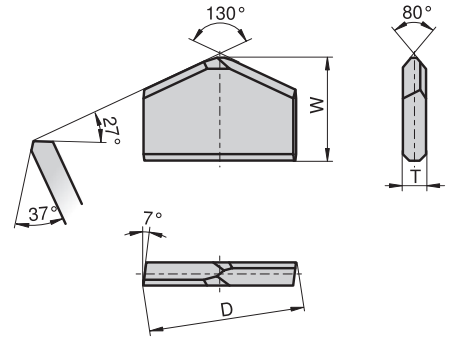

Ø [mm]	D [mm]	Tol. [mm]	W [mm]	Tol. [mm]	T [mm]	Tol. [mm]	α	β	γ
12.0	12.0	+0.43 / +0.23	8.2	+0.30	1.8	-0.15	27°	37°	7°
13.0	13.0	+0.43 / +0.23	8.7	+0.30	2.0	-0.15	27°	37°	7°
14.0	14.0	+0.43 / +0.23	9.3	+0.30	2.1	-0.18	27°	37°	7°
15.0	15.0	+0.43 / +0.23	9.6	+0.30	2.2	-0.18	27°	37°	7°
16.0	16.0	+0.43 / +0.23	9.6	+0.50	2.2	-0.18	27°	37°	7°
17.0	17.0	+0.43 / +0.23	10.5	+0.50	2.2	-0.18	27°	37°	7°
18.0	18.0	+0.43 / +0.23	10.5	+0.50	2.2	-0.18	27°	37°	7°
19.0	19.0	+0.43 / +0.23	11.5	+0.50	2.5	-0.18	27°	37°	7°
20.0	20.0	+0.52 / +0.24	11.5	+0.50	2.5	-0.20	27°	37°	7°
22.0	22.0	+0.52 / +0.24	12.5	+0.50	2.5	-0.20	27°	37°	7°
24.0	24.0	+0.52 / +0.24	15.0	+0.50	3.0	-0.20	27°	37°	7°
25.0	25.0	+0.52 / +0.24	15.0	+0.50	3.0	-0.20	27°	37°	7°
26.0	26.0	+0.52 / +0.24	15.0	+0.50	3.0	-0.20	27°	37°	7°
28.0	28.0	+0.52 / +0.24	15.0	+0.50	4.0	-0.20	27°	37°	7°
30.0	30.0	+0.52 / +0.24	16.0	+0.50	4.0	-0.20	27°	37°	7°

Codification code example: 16000- 12.0 CTM17-BC

Masonry drill tips – ANSI 28500 Inch

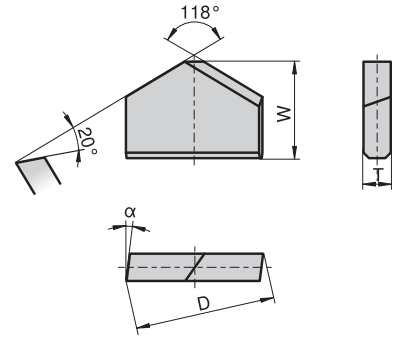
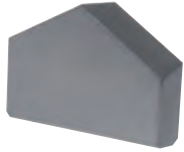

Ø [inch]	D [inch]	Tol. [inch]	W [inch]	Tol. [inch]	T [inch]	Tol. [inch]	α
1/8"	0.140	-0.006	0.138	+0.010	0.035	-0.003	9°
5/32"	0.171	-0.006	0.158	+0.010	0.035	-0.003	9°
3/16"	0.206	-0.008	0.177	+0.010	0.045	-0.003	8°
1/4"	0.268	-0.008	0.197	+0.010	0.060	-0.003	8°
5/16"	0.335	-0.008	0.236	+0.010	0.060	-0.003	7°
3/8"	0.398	-0.008	0.276	+0.010	0.078	-0.003	7°
1/2"	0.530	-0.010	0.335	+0.015	0.091	-0.004	7°
5/8"	0.660	-0.010	0.394	+0.015	0.091	-0.004	7°
3/4"	0.787	-0.012	0.473	+0.015	0.091	-0.004	7°
7/8"	0.917	-0.012	0.532	+0.015	0.091	-0.004	7°
1"	1.042	-0.012	0.575	+0.015	0.122	-0.005	7°
1 1/8"	1.175	-0.018	0.630	+0.020	0.122	-0.008	7°
1 1/4"	1.300	-0.018	0.650	+0.020	0.122	-0.008	7°
1 3/8"	1.425	-0.018	0.689	+0.020	0.122	-0.008	7°
1 1/2"	1.550	-0.018	0.709	+0.020	0.122	-0.008	7°

Codification code example: 28500- 1/8" CTM17-BC

28500

Ø [inch]	D [mm]	Tol. [mm]	W [mm]	Tol. [mm]	T [mm]	Tol. [mm]	α
1/8"	3.55	-0.15	3.5	+0.25	0.89	-0.07	9°
5/32"	4.34	-0.15	4.0	+0.25	0.89	-0.07	9°
3/16"	5.23	-0.20	4.5	+0.25	1.15	-0.07	8°
1/4"	6.80	-0.20	5.0	+0.25	1.52	-0.07	8°
5/16"	8.50	-0.20	6.0	+0.25	1.52	-0.07	7°
3/8"	10.10	-0.20	7.0	+0.25	1.98	-0.07	7°
1/2"	13.46	-0.25	8.5	+0.38	2.31	-0.10	7°
5/8"	16.76	-0.25	10.0	+0.38	2.31	-0.10	7°
3/4"	19.98	-0.30	12.0	+0.38	2.31	-0.10	7°
7/8"	23.29	-0.30	13.5	+0.38	2.31	-0.10	7°
1"	26.46	-0.30	14.6	+0.38	3.09	-0.12	7°
1 1/8"	29.84	-0.45	16.0	+0.50	3.09	-0.20	7°
1 1/4"	33.02	-0.45	16.5	+0.50	3.09	-0.20	7°
1 3/8"	36.19	-0.45	17.5	+0.50	3.09	-0.20	7°
1 1/2"	39.37	-0.45	18.0	+0.50	3.09	-0.20	7°

Codification code example: 28500- 1/8" CTM17-BC

Masonry drill tips – METRIC 46716

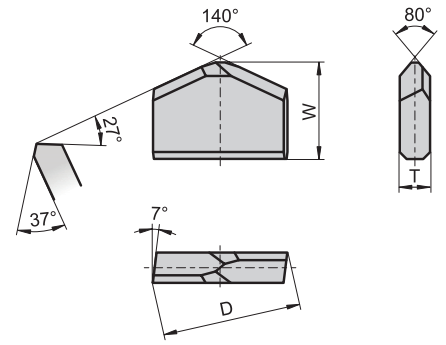
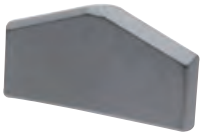

\varnothing [mm]	D [mm]	Tol. [mm]	W [mm]	Tol. [mm]	T [mm]	Tol. [mm]
6.0	6.240	± 0.060	3.90	± 0.10	1.050	± 0.050
6.5	6.740	± 0.060	4.40	± 0.10	1.050	± 0.050
8.0	8.285	± 0.075	5.15	± 0.15	1.125	± 0.050
10.0	10.285	± 0.075	5.55	± 0.15	1.325	± 0.075

Codification code example: 46716- 6.0 CTM14-BC

Masonry drill tips – METRIC 50210

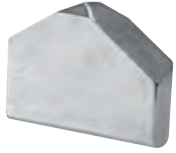

Conforming to PGM

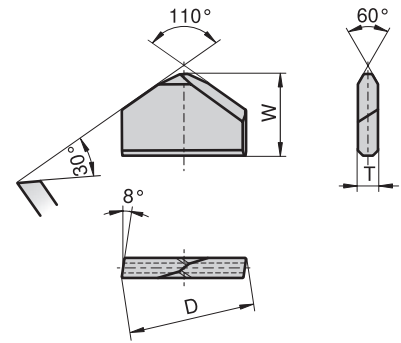

Ø [mm]	D [mm]	Tol. [mm]	W [mm]	Tol. [mm]	T [mm]	Tol. [mm]
4.0	4.0	+0.40 / +0.15	3.40	+0.20	1.0	-0.07
4.5	4.5	+0.40 / +0.15	3.90	+0.20	1.0	-0.07
5.0	5.0	+0.40 / +0.15	4.30	+0.20	1.2	-0.07
5.5	5.5	+0.40 / +0.15	4.70	+0.20	1.2	-0.07
6.0	6.0	+0.40 / +0.15	5.20	+0.20	1.4	-0.10
6.5	6.5	+0.40 / +0.15	5.70	+0.20	1.4	-0.10
7.0	7.0	+0.45 / +0.20	6.10	+0.20	1.6	-0.10
8.0	8.0	+0.45 / +0.20	6.05	+0.30	1.8	-0.10
10.0	10.0	+0.45 / +0.20	7.60	+0.30	2.2	-0.15
12.0	12.0	+0.50 / +0.20	9.35	+0.30	2.0	-0.15
13.0	13.0	+0.50 / +0.20	10.05	+0.30	2.2	-0.15
14.0	14.0	+0.50 / +0.20	10.85	+0.30	2.5	-0.18
16.0	16.0	+0.50 / +0.20	10.90	+0.50	2.5	-0.18
18.0	18.0	+0.50 / +0.20	12.10	+0.50	3.0	-0.18
20.0	20.0	+0.55 / +0.20	13.45	+0.50	3.2	-0.20
22.0	22.0	+0.55 / +0.20	13.70	+0.50	3.5	-0.20
25.0	25.0	+0.55 / +0.20	15.50	+0.50	4.1	-0.20

Codification code example: 50210- 4.0 CTF11-BC

Special tips
Sonderplatten
Plaquettes spéciales
Plachette non standard
Puntas especiales

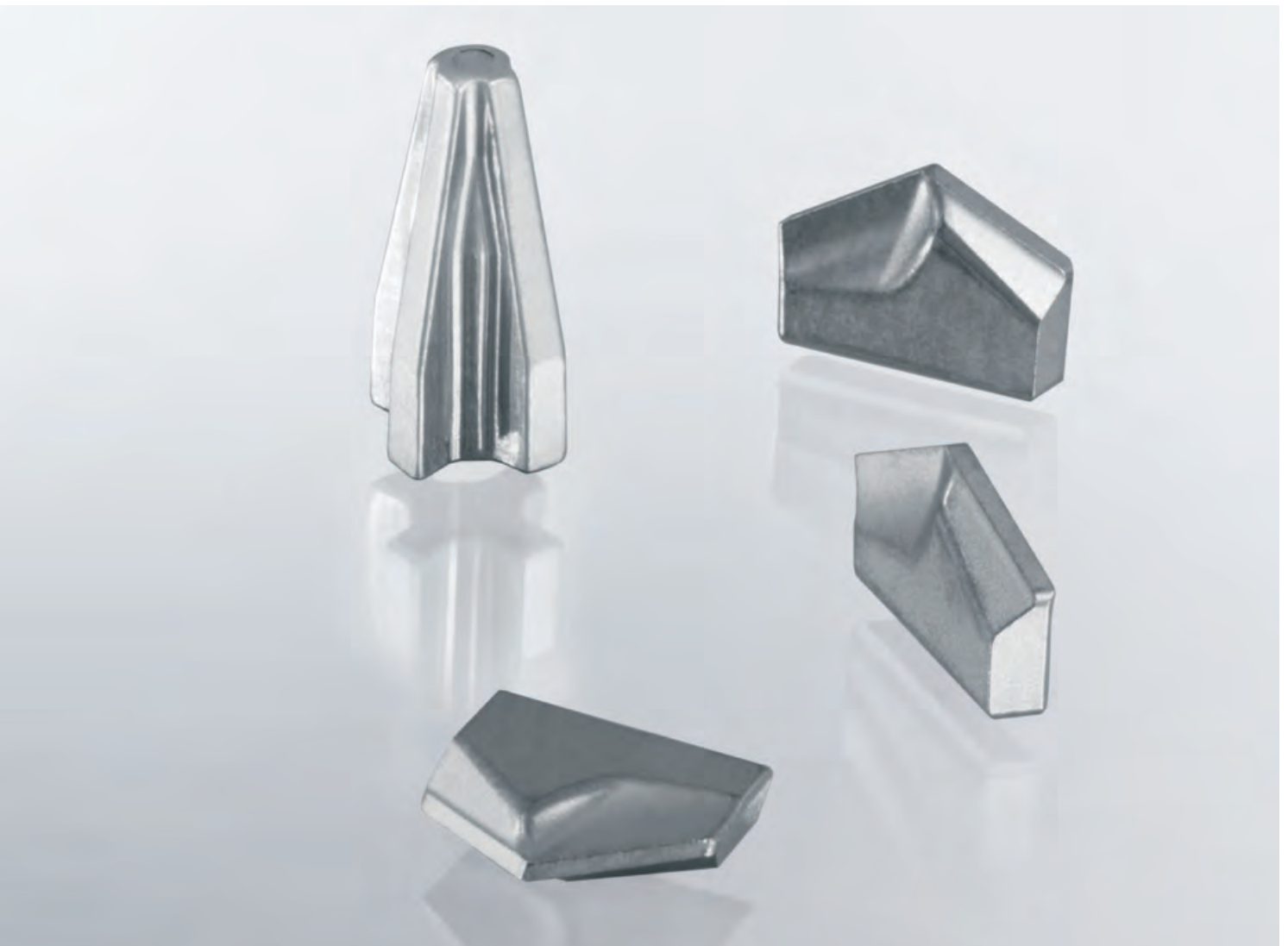

Index

METAL CUTTING TIPS Page

Applications 60

Metal Cutting Tips	Style	Range Ø	PGM Conformity	Page
12500	METRIC (Ø mm)	3 – 8		61
14818	METRIC (Ø mm)	8 – 23		61

WOOD WORKING TIPS Page

Applications 62

Wood working tips	Style	Range Ø	PGM Conformity	Page
CTDD RI/LE	METRIC (Ø mm)	4 – 20		63
CTDT RI/LE	METRIC (Ø mm)	4 – 20		64
CTDP	METRIC (Ø mm)	5 – 16		65
CTDT	METRIC (Ø mm)	15 – 60		65

GLASS DRILLING TIPS Page

Applications 66

Glass drilling tips	Style	Range Ø	PGM Conformity	Page
17353	METRIC (Ø mm)	3 – 13		67
50278	METRIC (Ø mm)	4 – 10		67

Metal cutting tips

Metallbohrerplatten

Plaquettes pour coupe métaux

Plaquette per punte per lavorazione metall

Puntas de broca para metal

Applications



Type, description	METRIC	Metal
12500	✓	○
14818	✓	●

- Optimum
- Not optimum

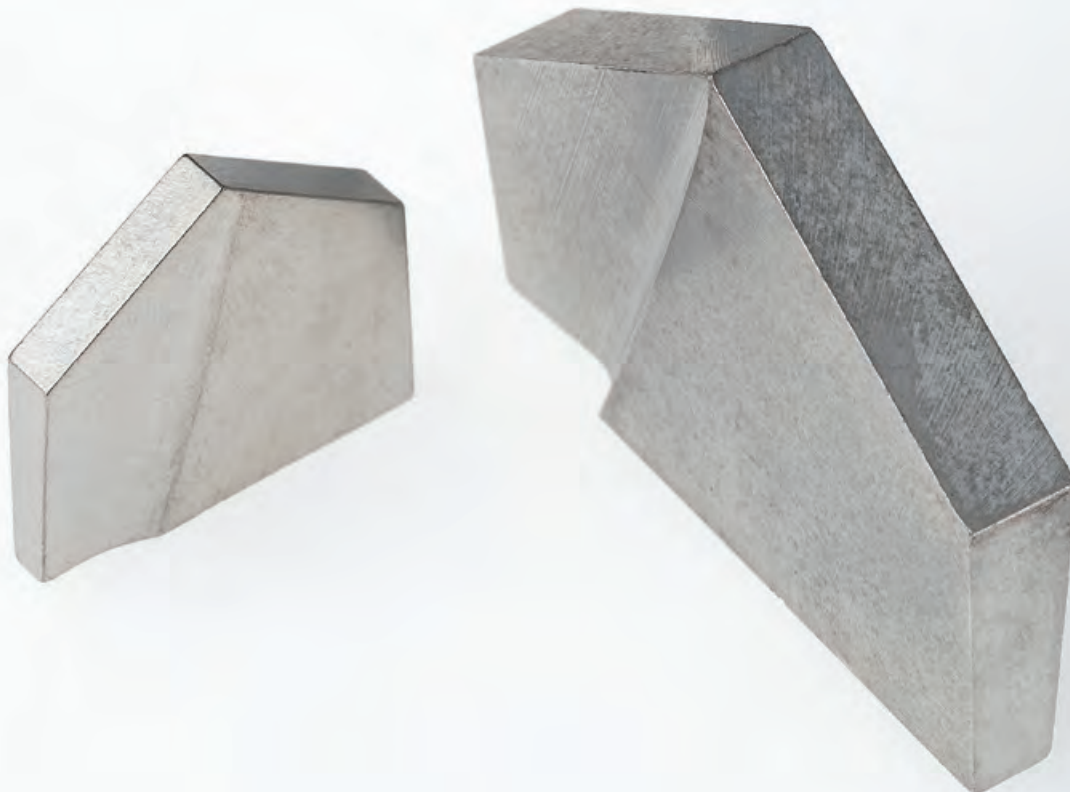

Metal cutting tips – METRIC

12500

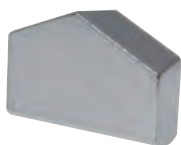

Grade recommendation:
CTS20-BC
CTS18D

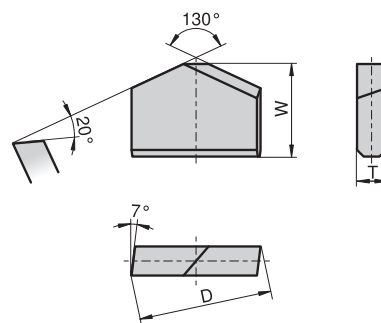

Ø [mm]	D [mm]	Tol. [mm]	W [mm]	Tol. [mm]	T [mm]	Tol. [mm]
3.0	3.0	+0.25 / +0.15	3.2	+0.20	0.8	-0.07
3.5	3.5	+0.25 / +0.15	3.6	+0.20	1.0	-0.07
4.0	4.0	+0.30 / +0.18	3.2	+0.20	1.0	-0.07
4.5	4.5	+0.30 / +0.18	3.6	+0.20	1.0	-0.07
5.0	5.0	+0.30 / +0.18	4.0	+0.20	1.2	-0.07
5.5	5.5	+0.30 / +0.18	4.4	+0.20	1.2	-0.07
6.0	6.0	+0.30 / +0.18	4.8	+0.20	1.4	-0.10
6.5	6.5	+0.30 / +0.18	5.2	+0.20	1.4	-0.10
7.0	7.0	+0.36 / +0.21	5.6	+0.20	1.6	-0.10
7.5	7.5	+0.36 / +0.21	6.0	+0.20	1.6	-0.10
8.0	8.0	+0.36 / +0.21	5.6	+0.30	1.8	-0.10

Codification code example: 12500- 3.0 CTS18-D

14818



Grade recommendation:
CTS20-BC
CTS18D

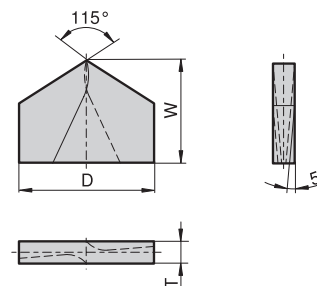

Ø [mm]	D [mm]	Tol. [mm]	W [mm]	T [mm]	Tol. [mm]
8.0	8.5	+0.5	7.1	1.6	-0.15
8.5	9.0	+0.5	8.0	2.0	-0.15
9.0	9.5	+0.5	8.0	2.0	-0.15
9.5	10.0	+0.5	8.5	2.0	-0.15
10.0	10.5	+0.5	8.5	2.0	-0.20
10.5	11.3	+0.5	9.5	2.2	-0.20
11.0	11.8	+0.5	9.5	2.2	-0.20
11.5	12.3	+0.6	10.6	2.5	-0.20
12.0	12.8	+0.6	10.6	2.5	-0.20
13.0	13.8	+0.6	12.5	2.5	-0.20
14.0	14.8	+0.7	12.5	2.5	-0.20
15.0	15.8	+0.7	14.0	2.8	-0.25
16.0	16.8	+0.7	14.0	2.8	-0.25
17.0	17.8	+0.7	16.0	3.0	-0.25
18.0	18.8	+0.7	16.0	3.0	-0.25
19.0	19.8	+0.7	18.0	3.5	-0.30
20.0	20.8	+0.8	18.0	3.5	-0.30
21.0	22.8	+0.8	18.0	3.5	-0.30
22.0	23.0	+0.8	19.0	4.0	-0.30
23.0	24.0	+0.8	19.0	4.0	-0.30

Codification code example: 14818- 8.0 CTS18-D

Blanks for wood machining drill tips

Rohlinge für Holzbohrer

Ébauches pour mèches à bois

Placchette per punte per cerniere

Preformados para brocas de madeira

Applications



Type, description	METRIC	Wood
CTDD RI / LE	✓	●
CTDD RI / LE	✓	●
CTDP	✓	●
CTDP	✓	●

- Optimum
- Not optimum



Blanks for wood machining drill tips – METRIC

CTDD RI

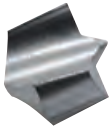

Grade recommendation:
HC35

Ø [mm]	D [mm]	Tol. [mm]	L [mm]	Tol. [mm]	R [mm]
4.0	4.6	x	6.9	x	1.3
5.0	5.6	x	7.1	x	1.8
6.0	6.6	x	7.1	x	2.2
6.5	7.1	x	7.7	x	2.7
7.0	7.6	x	7.9	x	2.7
8.0	8.6	x	9.1	x	3.2
9.0	9.6	x	10.1	x	3.7
10.0	10.6	x	11.0	x	4.2
11.0	11.6	x	11.9	x	4.2
12.0	12.6	x	12.8	x	4.3
13.0	13.6	x	13.6	x	4.5
14.0	14.6	x	14.4	x	4.7
15.0	15.6	x	15.2	x	5.0
16.0	16.6	x	16.0	x	5.2
18.0	18.6	x	16.2	x	5.6
19.0	19.6	x	17.5	x	6.1
20.0	20.6	x	19.1	x	6.7

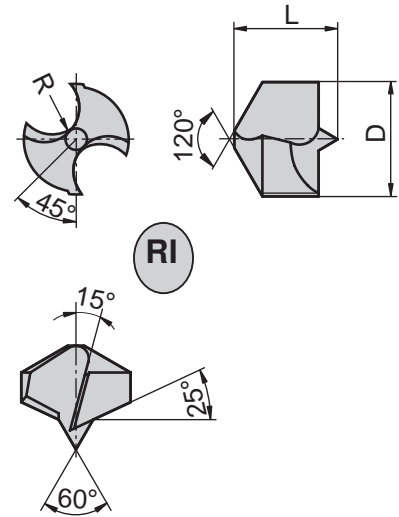

CTDD LE

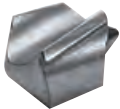

Grade recommendation:
HC35

Ø [mm]	D [mm]	Tol. [mm]	L [mm]	Tol. [mm]	R [mm]
4.0	4.6	x	6.9	x	1.3
5.0	5.6	x	7.1	x	1.8
6.0	6.6	x	7.1	x	2.2
6.5	7.1	x	7.7	x	2.7
7.0	7.6	x	7.9	x	2.7
8.0	8.6	x	9.1	x	3.2
9.0	9.6	x	10.1	x	3.7
10.0	10.6	x	11.0	x	4.2
11.0	11.6	x	11.9	x	4.2
12.0	12.6	x	12.8	x	4.3
13.0	13.6	x	13.6	x	4.5
14.0	14.6	x	14.4	x	4.7
15.0	15.6	x	15.2	x	5.0
16.0	16.6	x	16.0	x	5.2
18.0	18.6	x	16.2	x	5.6
19.0	19.6	x	17.5	x	6.1
20.0	20.6	x	19.1	x	6.7

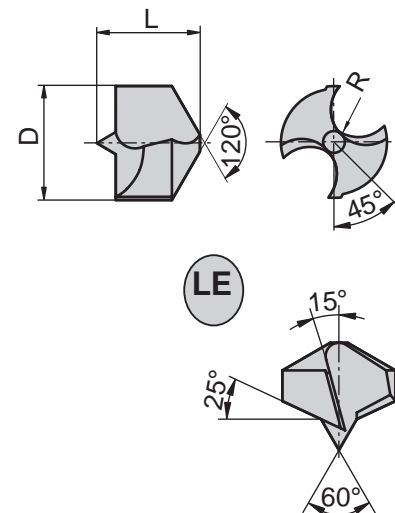

Codification code example: CTDD..RI- 4.0 CTS18-D

Blanks for wood machining drill tips – METRIC

CTDT RI

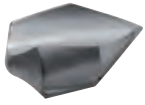

Grade recommendation:
HC35

Ø [mm]	D [mm]	Tol. [mm]	L [mm]	Tol. [mm]	R [mm]
4.0	4.5	x	9.0	x	1.3
5.0	5.6	x	10.5	x	1.8
6.0	6.6	x	11.5	x	2.2
6.5	7.1	x	12.2	x	2.7
7.0	7.6	x	13.0	x	2.7
8.0	8.6	x	14.5	x	3.2
9.0	9.6	x	16.8	x	3.7
9.5	10.1	x	17.7	x	3.7
10.0	10.6	x	18.7	x	4.2
11.0	11.6	x	21.0	x	4.2
12.0	12.6	x	22.1	x	4.3
13.0	13.6	x	24.3	x	4.5
14.0	14.6	x	25.5	x	4.7
15.0	15.6	x	26.0	x	5.0
16.0	16.6	x	27.0	x	5.2
18.0	18.6	x	28.0	x	5.6
20.0	20.6	x	33.5	x	6.7

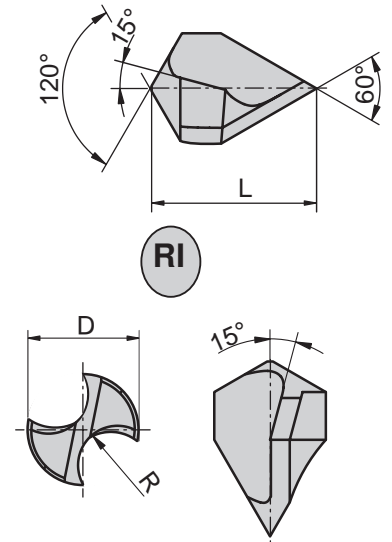

CTDT LE

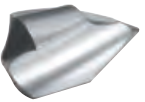

Grade recommendation:
HC35

Ø [mm]	D [mm]	Tol. [mm]	L [mm]	Tol. [mm]	R [mm]
4.0	4.5	x	9.0	x	1.3
5.0	5.6	x	10.5	x	1.8
6.0	6.6	x	11.5	x	2.2
6.5	7.1	x	12.2	x	2.7
7.0	7.6	x	13.0	x	2.7
8.0	8.6	x	14.5	x	3.2
9.0	9.6	x	16.8	x	3.7
9.5	10.1	x	17.7	x	3.7
10.0	10.6	x	18.7	x	4.2
11.0	11.6	x	21.0	x	4.2
12.0	12.6	x	22.1	x	4.3
13.0	13.6	x	24.3	x	4.5
14.0	14.6	x	25.5	x	4.7
15.0	15.6	x	26.0	x	5.0
16.0	16.6	x	27.0	x	5.2
18.0	18.6	x	28.0	x	5.6
20.0	20.6	x	33.5	x	6.7

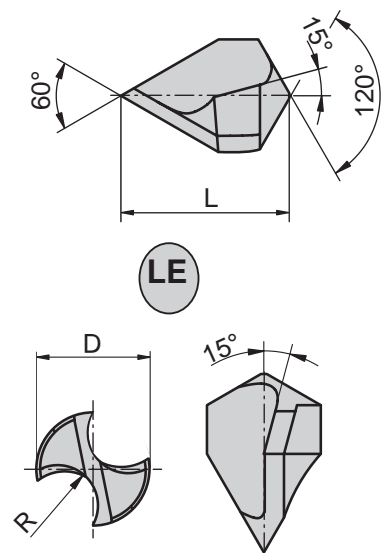

Codification code example: CTDT..RI- 4.0 CTS18-D

Blanks for wood machining drill tips – METRIC

CTDP

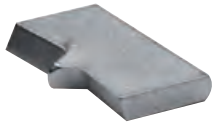

Grade recommendation:
HC30

Hole Ø [mm]	D [mm]	Tol. [mm]	W [mm]	Tol. [mm]	T [mm]
5	5.20	x	4.5	x	1.2
6	6.20	x	5.0	x	1.2
8	8.25	x	6.0	x	1.5
10	10.25	x	7.0	x	1.8
12	12.30	x	8.0	x	2.0
14	14.30	x	9.0	x	2.2
15	15.30	x	10.0	x	2.2
16	16.30	x	10.0	x	2.5

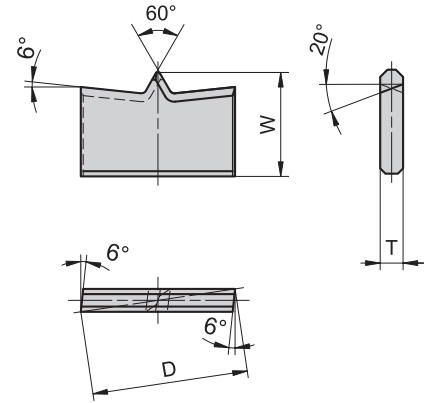

Codification code example: CTDP- 5.0 CTS18-D

CTDT

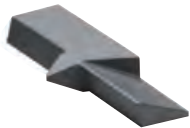

Grade recommendation:
HC30

Hole Ø [mm]	D [mm]
15	16
20	21
25	26
30	31
35	36
40	41
50	51
60	61

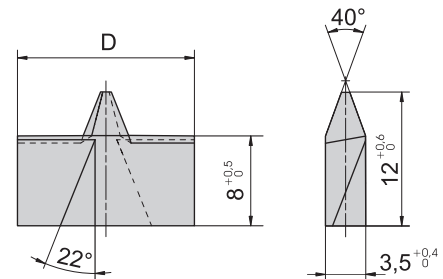

Codification code example: CTDT- 15.0 CTS18-D

Glass drill tips

Glasbohrerplatten

Plaquettes mèche pour le travail du verre

Placchette per punte per lavorazione vetro

Puntas de broca para vidrio

Applications



Type, description	METRIC	Glass	Tiles
17353	✓	●	●
50278	✓	●	●

● Optimum
○ Not optimum



Glass drill tips – METRIC

17353



Grade recommendation:
 CHROMIUM GRADE:
 CTS06-KC
 WC-Cobalt GRADE:
 CTF12-BC
 CTS15-E

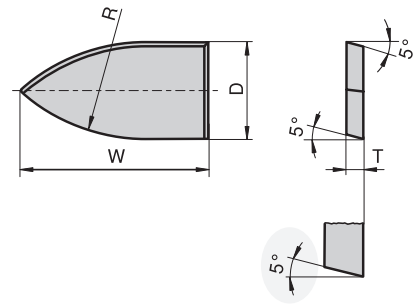

Ø [mm (inch)]	D [mm]	Tol. [mm]	W [mm]	Tol. [mm]	T [mm]	Tol. [mm]	R [mm]
3.0	3.4	-0.20	6.2	±0.20	1.1	-0.10	6
4.0	4.4	-0.20	8.2	±0.20	1.1	-0.10	8
5.0	5.4	-0.20	10.2	±0.20	1.3	-0.10	10
6.0	6.4	-0.20	12.2	±0.20	1.3	-0.10	12
6.5 (1/4")	6.8	-0.20	12.2	±0.20	1.5	-0.10	13
7.0	7.4	-0.25	14.2	±0.20	1.5	-0.10	14
8.0	8.4	-0.25	16.2	±0.20	1.8	-0.10	16
9.0	9.4	-0.25	18.2	±0.20	1.8	-0.10	18
10.0 (3/8")	10.4	-0.25	20.2	±0.20	1.8	-0.10	20
12.0	12.4	-0.25	24.2	±0.20	2.3	-0.10	24
13.0 (1/2")	13.4	-0.30	26.2	±0.20	2.3	-0.10	26

Codification code example: 17353- 3.0 CTF12-BC

50278



Grade recommendation:
 CHROMIUM GRADE:
 CTS06-KC
 WC-Cobalt GRADE:
 CTF12-BC
 CTS15-E

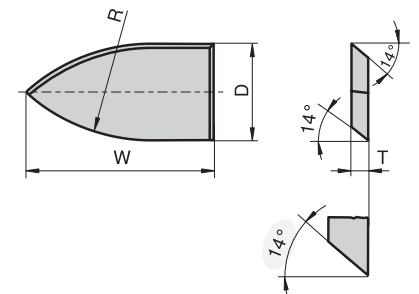

Ø [mm]	D [mm]	Tol. [mm]	W [mm]	Tol. [mm]	T [mm]	Tol. [mm]	R [mm]
4.0	4.4	-0.20	8.2	±0.10	1.1	-0.10	8
5.0	5.4	-0.20	10.2	±0.10	1.3	-0.10	10
6.0	6.4	-0.20	12.2	±0.15	1.3	-0.10	12
8.0	8.4	-0.30	16.2	±0.15	1.8	-0.10	16
10.0	10.4	-0.30	20.2	±0.20	1.8	-0.10	20

Codification code example: 50278- 4.0 CTF12-BC

Core drill tips

Bohrkronenplatten

Plaquettes pour trépan

Placchette per punte a corona

Plaquitas para trepano

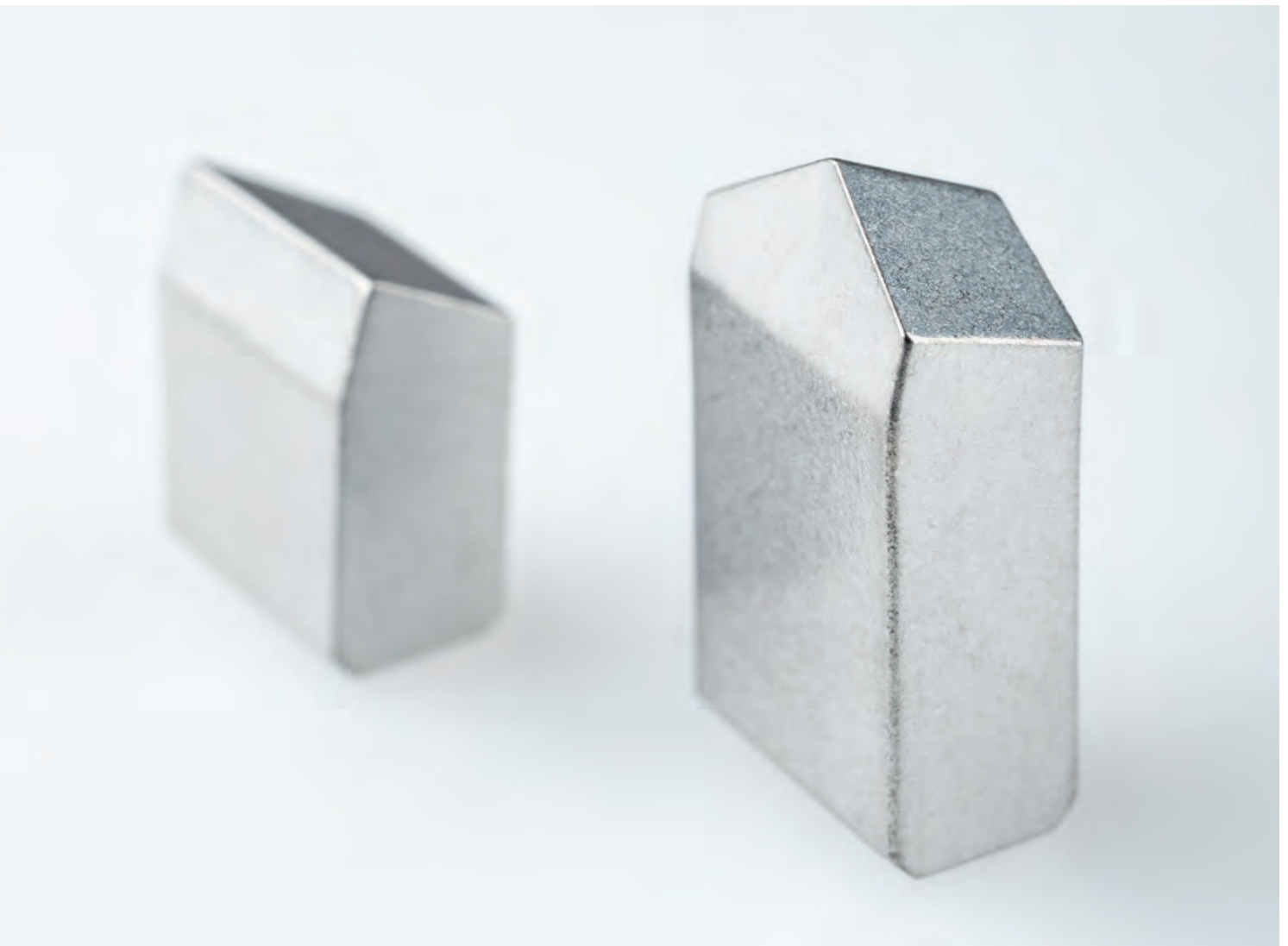

Index

Grades				Page
Composition and properties				70

Standard Core Drill Tips	Style	Range Ø	PGM Conformity	Page
12083	METRIC (Ø mm)	9.0 x 4.5 x 3.0		71
12641	METRIC (Ø mm)	9.0 x 6.5 x 4.0 10.0 x 6.5 x 4.0		71
13326	METRIC (Ø mm)	9.0 x 5.5 x 3.5		71
14420	METRIC (Ø mm)	10.0 x 5.0 x 3.5		71

With chamfer	Style	Range Ø	PGM Conformity	Page
14157	METRIC (Ø mm)	12.0 x 7.0 x 4.0		72
23985	METRIC (Ø mm)	8.0 x 6.6 x 4.1		72
28537	METRIC (Ø mm)	12.5 x 7.2 x 4.1		72
30838	METRIC (Ø mm)	8.1 x 7.1 x 4.1		72

With point	Style	Range Ø	PGM Conformity	Page
16623	METRIC (Ø mm)	8.5 x 6.5 x 3.9		73
39241	METRIC (Ø mm)	8.0 x 4.0 x 3.0 8.0 x 5.5 x 3.6		73
42067	METRIC (Ø mm)	10.3 x 5.0 x 3.0		73
50809	METRIC (Ø mm)	8.0 x 7.2 x 4.0 12.5 x 7.2 x 4.0		73

Grades for stone working – composition and properties

WC-Cobalt Grades

CERATIZIT grade code	ISO code	U.S. code	Binder [m %]	Density [g/cm ³]	Hardness			Transverse Rupture Strength	
					HV10	HV30	HRA	[MPa]	[P.S.I.]
Fine grain									
CTF12-BC	BC05	C2	6.0	14.95	1640	1620	92.1	2200	319.000
CTF24-BC	BC30	C11	12.0	14.30	1330	1320	89.7	3000	435.000
CTF30-BC	BC40	C13	15.0	14.05	1250	1240	88.8	3100	450.000
Medium grain									
CTM14-BC	BC10	C2	7.0	14.90	1550	1530	91.5	2600	377.000
CTM17-BC	BC20	C1	8.5	14.65	1420	1400	90.4	2800	406.000

Classification of the WC grain size

Average grain size [μm]	Classification	CERATIZIT- code
< 0.2	nano	N
0.2 – < 0.5	ultrafine	U
0.5 – < 0.8	submicron	S
0.8 – < 1.3	fine	F
1.3 – < 2.5	medium	M
2.5 – < 6.0	coarse	C
> 6.0	extra-coarse	E

Core drill tips – METRIC

12083

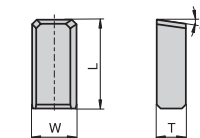

Codification [mm]	L [mm]	Tol. [mm]	W [mm]	Tol. [mm]	T [mm]	Tol. [mm]
9.0 x 4.5 x 3.0	9.0	±0.10	4.5	±0.05	3.0	-0.10

Codification code example: 12083- 9.0x4.5x3.0 CTM17-BC

12641

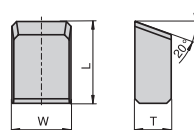

Codification [mm]	L [mm]	Tol. [mm]	W [mm]	Tol. [mm]	T [mm]	Tol. [mm]
9.0 x 6.5 x 4.0	9.0	±0.10	6.5	±0.07	4.0	±0.05
10.0 x 6.5 x 4.0	10.0	±0.10	6.5	±0.07	4.0	±0.05

Codification code example: 12641- 9.0x6.5x4.0 CTM17-BC

13326

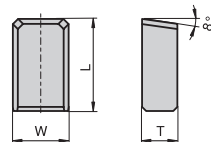

Codification [mm]	L [mm]	Tol. [mm]	W [mm]	Tol. [mm]	T [mm]	Tol. [mm]
9.0 x 5.5 x 3.5	9.0	±0.10	5.5	-0.10	3.5	-0.10

Codification code example: 13326- 9.0x5.5x3.5 CTM17-BC

14420

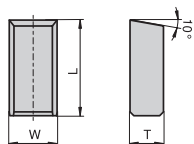

Codification [mm]	L [mm]	Tol. [mm]	W [mm]	Tol. [mm]	T [mm]	Tol. [mm]
10.0 x 5.0 x 3.5	10.0	±0.10	5.0	±0.10	3.5	±0.15

Codification code example: 14420- 10.0x5.0x3.5 CTM17-BC

Core drill tips – METRIC

14157

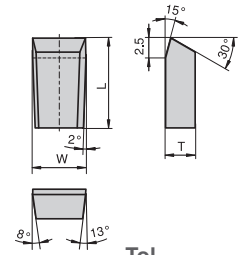

Codification [mm]	L [mm]	Tol. [mm]	W [mm]	Tol. [mm]	T [mm]	Tol. [mm]
12.0 x 7.0 x 4.0	12.0	±0.10	7.0	+0.20	4.0	-0.10

Codification code example: 14157- 12.0x7.0x4.0 CTF12-BC

23985

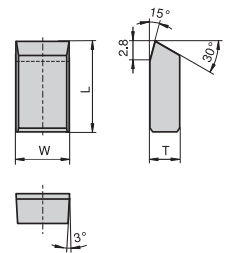

Codification [mm]	L [mm]	Tol. [mm]	W [mm]	Tol. [mm]	T [mm]	Tol. [mm]
8.0 x 6.6 x 4.1	8.0	±0.10	6.6	±0.10	4.15	-0.15

Codification code example: 23985- 8.0x6.6x4.1 CTF12-BC

28537

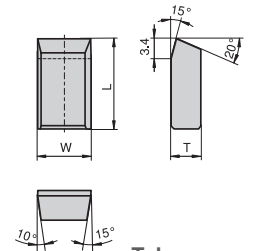

Codification [mm]	L [mm]	Tol. [mm]	W [mm]	Tol. [mm]	T [mm]	Tol. [mm]
12.5 x 7.2 x 4.1	12.5	±0.15	7.2	±0.20	4.1	-0.10

Codification code example: 28537- 12.5x7.2x4.1 CTF12-BC

30838

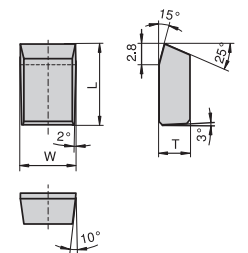

Codification [mm]	L [mm]	Tol. [mm]	W [mm]	Tol. [mm]	T [mm]	Tol. [mm]
8.1 x 7.1 x 4.1	8.1	±0.10	7.1	±0.10	4.1	-0.10

Codification code example: 30838- 8.1x7.1x4.1 CTF12-BC

Core drill tips – METRIC

16623

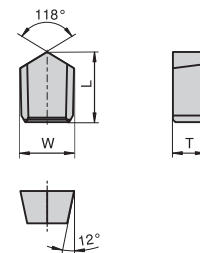

Codification [mm]	L [mm]	Tol. [mm]	W [mm]	Tol. [mm]	T [mm]	Tol. [mm]
8.5 x 6.5 x 3.9	8.5	±0.10	6.25	±0.05	3.915	±0.035

Codification code example: 16623- 8.5x6.5x3.9 CTM17-BC

39241

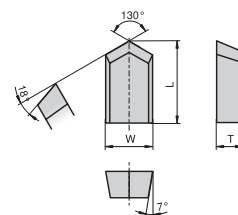

Codification [mm]	L [mm]	Tol. [mm]	W [mm]	Tol. [mm]	T [mm]	Tol. [mm]
8.0 x 4.0 x 3.0	8.0	±0.10	4.0	±0.10	3.0	±0.05
8.0 x 5.5 x 3.6	8.0	±0.10	5.5	±0.10	3.6	±0.05

Codification code example: 39241- 8.0x4.0x3.0 CTM17-BC

42067

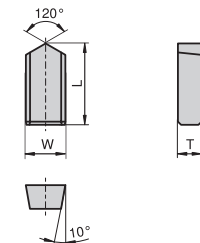

Codification [mm]	L [mm]	Tol. [mm]	W [mm]	Tol. [mm]	T [mm]	Tol. [mm]
10.3 x 5.0 x 3.0	10.3	±0.10	5.0	±0.10	3.0	±0.07

Codification code example: 42067- 10.3x5.0x3.0 CTM17-BC

50809

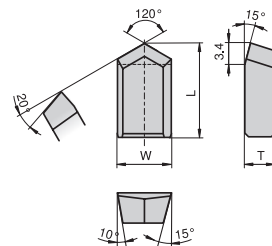

Codification [mm]	L [mm]	Tol. [mm]	W [mm]	Tol. [mm]	T [mm]	Tol. [mm]
8.0 x 7.2 x 4.0	8.0	±0.10	7.2	+0.20	4.1	-0.10
12.5 x 7.2 x 4.0	12.55	±0.15	7.2	+0.20	4.1	-0.10

Codification code example: 50809- 8.0x7.2x4.0 CTM17-BC

Fluterolls for drill production

Nutwalzrollen für Bohrerfertigung

Outils pour la fabrication de cannelures des forêts

Utensili per scanalatura per punte a forare

Rueda párrafo los taladros de la torcedura

SW5
SW6
SW10

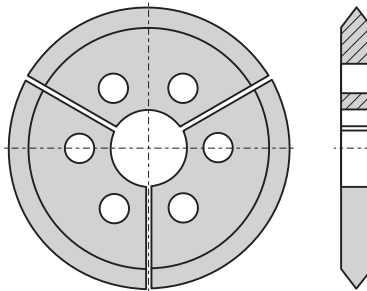

Codification

SW5
SW6
SW10

SW13
SW16

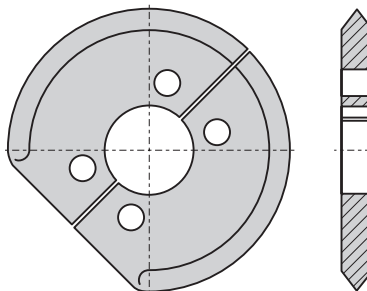

Codification

SW13
SW16

SW20

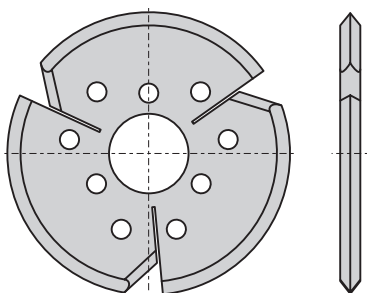

Codification

SW20

SPECIAL

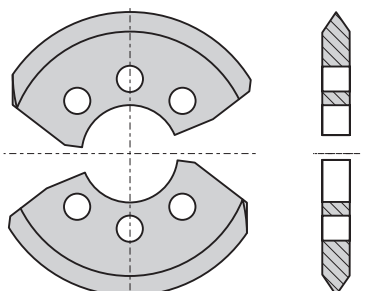

Codification

SPECIAL



Powder & grit
Pulver & Grit
Poudres & grit
Polvere & graniglia
Polvo & arenilla



Powder & grit

We also offer carbide powder with various grain sizes. You can choose from a variety of carbide grades with mechanical

properties tailored to the application. As well as the powder we also produce sharp-edged and flaky grit.

Tungsten carbide powder



Smallest packaging unit: 15 kg
Minimum order quantity: 100 kg

Grit – Available sharp-edged or in form of plates



Powder RTP (ready to press)



Smallest packaging unit: 15 kg
Minimum order quantity: 100 kg

Sharp-edged grit



Smallest packaging unit: 15 kg
Minimum order quantity: 100 kg

Technical specifications available upon request only

Product range

Material	Grain size [µm]
6010216	0.8 – 0.9
6010326	1.1 – 1.3
6010427	1.3 – 1.5
6010219	1.6 – 2.0
6010220	1.8 – 2.1
6010223	2.8 – 3.3
11469150	4.5 – 5.0
6010225	9.0 – 12.0
6010226	13.7 – 22.5

Product range

Material	Grain size [µm]
11982134	0.6 – 1.0
11738926	1.0 – 1.5
11793886	1.6 – 3.2
11793887	3.2 – 4.8
11793888	4.8 – 6.4
11793890	6.0 – 10.0

According to measuring standard FSSS

Index

1		B		S	
11384 – Metric	30	Blanks for wood machining		Special (Fluteroll)	74
11400 – Metric	43	drill tips – Metric	64–65	Special Tips	58–67
12083 – Metric	71	C		SW5	74
12500 – Metric	47, 61	CERATIZIT Style 58000	40	SW6	74
12641 – Metric	71	Core drill tips	68–73	SW10	74
13326 – Metric	71	CT4 – Ansi	25	SW13	74
14157 – Metric	72	CT4 – Japan	25	SW16	74
14420 – Metric	71	CT4 – Metric	24	SW20	74
14444 – Metric	34	CTDD..LE	63		
14818 – Metric	61	CTDD..RI	63		
16000 – Metric	54	CTDP	65		
16300 – Metric	50	CTDT	65		
16623 – Metric	73	CTDT..LE	64		
17353 – Metric	67	CTDT..RI	64		
17871 – Ansi	32	CTE20-BC	15		
17871 – Ansi Inch	31	CTE30-BC	15		
2		CTE35-BC	15		
22000 – Ansi	49	CTF08-BC	15, 22, 38		
22000 – Ansi Inch	48	CTF11-BC	15, 22, 38		
23500 – Metric	51	CTF12-BC	15, 22, 38, 40, 70		
23985 – Metric	72	CTF24-BC	15, 22, 38, 70		
24323 – Metric	52	CTF30-BC	15, 70		
26000 – Japan	33	CTM14-BC	15, 22, 38, 70		
28500 – Ansi	55	CTM17-BC	15, 22, 38, 70		
28500 – Ansi Inch	55	CTM18-BC	15		
28537 – Metric	72	CTS06-KC	15		
3		CTS20-BC	15		
30838 – Metric	72	F			
32222 – Metric	45	Fluterolls for drill production	74		
37071 – Metric	46	G			
38500 – Metric	34	Glass drill tips	66–67		
38911 – Metric	34	Grades for stone working	12, 22, 38, 70		
39241 – Metric	73	H			
39742 – Metric	35	Hammer drill tips	20–35		
4		I			
40429 – Metric	35	Innovation	16–19		
42067 – Metric	73	M			
43500 – Metric	53	Masonry drill tips	36–57		
46000 – Metric	26	Metal cutting tips	60–61		
46600 – Ansi	27	P			
46716 – Metric	56	Powder & grit	76–77		
46973 – Ansi	44				
47500 – Japan	28				
5					
50210 – Metric	57				
50809 – Metric	73				
50850 – Ansi	29				
50850 – Metric	29				
58000 – Metric	40				
58800 – Metric	42				

Headquarters:

CERATIZIT S.A.
LU-8232 Mamer
T. +352 31 20 85-1
E. info@ceratizit.com
www.ceratizit.com

